

CANADA'S HOME ELECTRIFICATION TOOLKIT

Your guide to a
cleaner, smarter,
more affordable
home



All Electric Alliance Canada



ELECTRIFY YOUR:

- | | | |
|-----------------|---------------------|----------------|
| 1 SPACE HEATING | 4 DRYERS | 7 EV CHARGERS |
| 2 WATER HEATING | 5 FIREPLACES | 8 BACKUP POWER |
| 3 COOKING | 6 OUTDOOR EQUIPMENT | 9 SOLAR POWER |

...AND
MORE!

CREDITS AND COPYRIGHT

By Heather McDiarmid, Building Decarbonization Alliance
Illustrations by Saje Damen

Version 1.1, released April 2025

Visit buildingdecarbonization.ca/canadas-home-electrification-toolkit for digital downloads, updates, and other information about home electrification.

All reasonable precautions have been taken by the Building Decarbonization Alliance to verify the information in this publication. However, the published material is being distributed without warranty of any kind, either expressed or implied. The responsibility for the interpretation and use of the material lies with the reader. In no event shall the Building Decarbonization Alliance be liable for damages arising from its use.

Copyright © 2026 The Building Decarbonization Alliance

Released under a Creative Commons CC-BY-NC-SA 4.0 license. You are free to adapt and share this document with the following terms:

- **Attribution:** You must give appropriate credit, provide a link to the license, and indicate if changes were made. You may do so in any reasonable manner, but not in any way that suggests the Building Decarbonization Alliance endorses you or your use.
- **NonCommercial:** You may not use the material for commercial purposes .
- **ShareAlike:** If you remix, transform, or build upon the material, you must distribute your contributions under the same license as the original.
- **No additional restrictions:** You may not apply legal terms or technological measures that legally restrict others from doing anything the license permits.

Table of Contents

1	Introduction	56	Solar Power
6	How to Read This Toolkit	62	Avoiding an Electrical Panel Upgrade
8	Space Heating	67	Energy Management Systems
18	Electric Thermal Storage	72	Options for Renters
22	Water Heaters	76	Electrification Incentives
29	Cooking	79	Amplifying the Impact Through Conversations
34	Dryers	80	Ways Community Groups Can Help
39	Fireplaces	82	Appendices
42	Outdoor Equipment	87	Endnotes
47	EV Chargers		
52	Home Batteries and Backup Generators		

Introduction

Your home is your castle. It is a safe space where you can relax, add your personal touches and pursue your interests.

Your home is likely also your largest financial investment or monthly expense, and sadly, it can also be your largest source of greenhouse gas (GHG) emissions. In fact, buildings are Canada's third-largest source of GHG emissions. Much of that comes from the natural gas, oil and propane used to provide space and water heating. But other equipment in and around our homes also uses fossil fuels, such as gas stoves, fireplaces, lawnmowers, and generators.

The good news is that electrifying this equipment can significantly lower your emissions—along with providing many other benefits for you and your family. Electric equipment often means greater energy efficiency, improved home comfort, reduced noise pollution and even long-term cost savings.



The faster we can decarbonize—that is, eliminate GHG emissions from our homes—the better, because changes in the climate directly linked to GHG emissions have already impacted all of us through floods, forest fires, extreme heat, and erratic weather. Climate change has damaged infrastructure, polluted the air, damaged crops, and left vulnerable populations at risk, and it continues to escalate. The most credible and effective way to avoid the worst impacts in the future is to stop burning fossil fuels and switch to electric appliances, even in provinces that still use fossil fuels to generate electricity.

Fortunately, all-electric equipment has made significant advancements: modern heat pumps provide highly efficient and comfortable heating (and cooling) without the health and environmental risks of gas furnaces; induction cookers produce no indoor air pollutants; electric yard equipment is quieter than gas equipment; and energy management systems can significantly reduce your energy usage.

Nearly everyone can do something to electrify their home, whether you're an owner or a renter, and even with tight budget constraints. Planning for electrification and saving up for a future replacement are excellent strategies, especially when plans and accomplishments are shared with others. And for those who can afford it, transitioning to net-zero energy with efficient electric equipment plus solar panels is a great way to go. There are many opportunities to explore in this toolkit.

WHY A TOOLKIT?

Electrifying everything in and around your home can be daunting. There can be many options to choose from, you might need an electrician to upgrade the wiring or the electrical panel, and sometimes tradespeople will

INTRODUCTION

try to talk us out of our decisions because they are more comfortable installing the equipment that has been popular in the past.

With a bit of information and planning, these challenges can be overcome. It's well worth the effort, because electric equipment reduces emissions, improves air quality and home comfort, and generally makes our lives better.

This toolkit is designed to help you understand the electric options and factors you'll want to consider when replacing fuel-burning appliances. It is designed to empower you to build a plan for what equipment you will aim to replace and when, learn about electric equipment so that you can talk knowledgeably with tradespeople, and spread the word to inspire others to do the same.

BENEFITS OF ELECTRIFICATION

- Modern electric heat pumps and other equipment are usually more energy efficient than their fossil-fueled predecessors. This means we can get the same services from electric equipment while using less energy. When the electricity is generated from zero-emission sources, operating electric equipment produces no GHG emissions. Most of Canada already has low-emission electricity and plans are underway to further reduce the emissions from electricity generation.
- Because electric equipment uses less energy, it can lead to significant cost savings, especially in areas with lower electricity prices. This will be even more true in the future: as more homes and businesses disconnect from the natural gas system, gas will become more expensive because the costs of maintaining the infrastructure will be supported by a shrinking customer base.
- Improved health and safety are further benefits of electric equipment, since no gases are being burnt in your home. Carbon monoxide is not a risk in an all-electric home, and a home that switches out a gas stove will benefit from better indoor air quality and lower risk of respiratory ailments such as asthma.
- Electric equipment can also increase resilience to climate change. For example, heat pumps can heat and cool a home and protect vulnerable populations during the extreme heat events that are becoming more common with climate change. Solar panels with batteries, all-electric generators, and an increasing number of electric vehicles can provide electricity to power the essentials during a power outage (see [Sections 10](#) and [11](#) for details).
- Hydrogen and renewable natural gas have been proposed as alternative fuels for building use. However, these fuels are expected to be more expensive, more difficult to source, and have other challenges that make them less practical today for achieving net-zero emissions.¹ These fuels are best reserved for when electrification doesn't make sense (e.g. industrial applications where electrification is not currently a viable option). Many experts have looked at these alternatives and most, including the International Energy Agency, the Building Decarbonization Alliance and others, have concluded that electrification is the best no-regrets pathway for reducing emissions from buildings.
- Electrification is good for our society because it reduces air pollution, creates new jobs in manufacturing and skilled trades, and limits climate change.

CHALLENGES OF ELECTRIFICATION

- In many cases, electric equipment costs more up front than fueled equipment, but they often save money over their lifetimes due to higher efficiencies. It helps to plan ahead to replace equipment near its end of life and take advantage of incentives and low-cost financing opportunities.
- Many people are concerned about operating their home during a power outage. If everything is electrified, nothing will work when the power is out—unless you have a battery, generator, or in some cases an electric vehicle (EV) (see [Section 9](#)). Keep in mind that many gas appliances, including furnaces, also will not operate during a power outage for safety reasons.

INTRODUCTION

- Some critics have raised concerns about the impacts on Canada's electricity grid as we shift to powering our homes and vehicles with electricity. While provinces and territories will have to invest in new, low-carbon electricity generation as our society moves towards electrification, this process is already underway, and tools like demand management, energy storage and even storing heat will also be part of the solution. Residents should not hesitate to look into electrification, especially as equipment reaches its end of life.
- While many installers and salespeople will be helpful and supportive of your electrification plans, some may present a challenge to the adoption of

electric equipment. In some regions, there may be a lack of skilled labour trained to install electric equipment. When tradespeople are used to selling traditional fueled equipment, they may have outdated perceptions of electric alternatives and may try to talk you out of electric options. It is important to know that electric equipment is typically just as reliable as the fueled version and offers many co-benefits for health, comfort, and the environment. If you encounter resistance to electrified equipment, consider finding a different installer or salesperson who is informed about the newest electrified options and who can help you to select equipment that meets your needs and priorities.

PLANNING YOUR ELECTRIFICATION JOURNEY

Planning ahead can streamline the process of electrifying your home and its surroundings. Here is a general strategy that you can apply:

1. Identify what you want to electrify now and what your longer-term plans are:

Inventory all fueled equipment in and around your home, including its age and condition, and who owns the equipment (you, a rental service, or the building owner). Read up on the equipment that you plan to electrify, starting with the chapters in this toolkit. If you are a renter, be sure to check out [Section 14](#).

Equipment	Typical lifespan for gas equipment (yrs)	Age/condition	Who owns the equipment?	Budget needed	Plan to electrify?
Heating system	15-20			\$\$\$-\$\$\$\$	
Cooling system	15-20			\$\$\$-\$\$\$\$	
Water heater	10-15			\$\$-\$\$\$	
Stove	10-15			\$\$-\$\$\$	
Dryer	10-13			\$\$-\$\$\$	
Fireplace	10-25			\$\$-\$\$\$	
Yard equipment	5-10			\$\$-\$\$\$	
BBQ	5-15			\$\$	
Other					

INTRODUCTION

2. Check your electrical panel and wiring to assess if upgrades are needed (see [Section 12](#)).

If you are switching from a fueled appliance, you'll need to ensure that a compatible outlet is available near where the electric appliance will be installed. You can save time and money by having an electrician pre-wire all new outlets at once.

3. Consider getting a home energy audit.

This personalized assessment can identify the most effective strategies for improving the insulation and air quality of your home while finding issues that could become problematic in the long term. While it is not necessary to perform these home improvements before electrifying, they can help to save money on heating and cooling, improve the comfort of your home, and reduce the size (and cost) of heating system you'll need. Plus, many home incentive programs will require a home energy audit before and after home improvements are carried out.

4. Explore prices, incentives, and financing.

Having a rough idea of costs beforehand can help with budgeting and allow you to act fast when equipment fails or when attractive incentives become available.

5. Get quotes from multiple sources

When ready to replace equipment, always get quotes or prices from multiple reliable sources. Your friends and neighbours may be great resources.

6. Celebrate and share your electrification journey with others (see [Sections 16 and 17](#)).

Such milestones are worth celebrating, and you may even inspire others to electrify too. The sooner we collectively stop burning fossil fuels, the safer the future will be for everyone.

Let your
electrification
journey begin!

Additional Resources:

**[Electrify Now: How to get started
\(electrifying a home\)](#)**

List of Abbreviations

All abbreviations are described in the text the first time they are used.

AC	Alternating current (air conditioning is always written out in full here)
ASHP	Air source heat pump
ccASHP	Cold climate air source heat pump
COP	Coefficient of performance
DC	Direct current
ERV	Energy recovery ventilator
ETS	Electric thermal storage
EV	Electric vehicle
GHG	Greenhouse gas
GSHP	Ground source heat pump
GWP	Global warming potential
HRV	Heat recovery ventilator
HSPF	Heating system performance factor
PV	Photovoltaic
SEER	Seasonal energy efficiency ratio
UEF	Uniform energy factor
V2G	Vehicle-to-grid
V2H	Vehicle-to-home
V2L	Vehicle-to-load

1.

How to Read This Toolkit

Each section in the Home Electrification Toolkit describes either a household appliance or an action that you can take within your living space. The “At a Glance” section offers a quick summary of the cost, electrical needs, lifespan, level of complexity, GHG reductions, ideas for renters, and a few key considerations regarding each item. A description of the terms and symbols used is provided below. If you rent your home, see [Section 14](#) for tailored insights.

The different electric options are described in each section followed by information on the benefits, challenges and other considerations when selecting an electric option. Links to further resources and questions for installers are also provided throughout the toolkit.

[Section 12](#), on avoiding an electrical panel upgrade, aims to enhance your understanding of your electrical panel—identifying the outlet types commonly used for appliances, while potentially saving you money in the process.

Be sure to also check out [Sections 16](#) and [17](#) to learn how everyday conversations and group activities can amplify your influence.

Finally, the [appendices](#) highlight province-specific outcomes for operating costs relative to gas equipment and emissions reductions for each primary toolkit item, along with details of the methodology employed.

The following symbols and terms will be used through the report:

Upfront or operating cost (no incentives applied)

Symbol	Description
\$	Up to \$99
\$\$	\$100-\$999
\$\$\$	\$1,000-\$9,999
\$\$\$\$	\$10,000 and above

Implementation

Term	Description
Easy	Can be implemented by yourself if no electrical upgrade is required
Medium	Can be implemented by someone with DIY skills
Difficult	Generally requires a qualified electrician or other contractor

Emissions reduction potential (onsite emissions reductions using Canadian averages)

Term	Description
Low	1-9 kg CO2 per year
Medium	10-99 kg CO2 per year
High	100-999 kg CO2 per year
Very high	> 1,000 kg CO2 per year

When comparing electric to gas equipment on upfront costs, operating costs and emissions

Symbol	Description
=	Values differ by 10% or less
▽	Electric version is 10-50% lower
▼	Electric version is more than 50% lower
△	Electric version is 10-100% higher
▲	Electric version is more than 100% higher

Space Heating at a glance

COST

Upfront costs:
\$\$\$-\$\$\$\$

Annual operating costs:
\$\$-\$\$\$

EFFICIENCY

200-500%

ELECTRICAL NEEDS

240V*

*amp requirements vary
by size and design

Links to further resources:

- [Information on heat pumps](#)
- [Information on building envelope improvements](#)
- [Canadian Association of Consulting Energy Advisors Directory](#)

EQUIPMENT LIFESPAN

15-20 years

IMPLEMENTATION

Difficult

EMISSIONS REDUCTION IMPACT

Very high

RENTERS

Consider a portable heat
pump

BONUS

Improved home comfort

2.

Space Heating

“

Heat pumps are the now of home heating.

— Paul Dowsett, Architect
and Pocket Change Project Retrofit Coach

Heat pumps exchange heat energy with the outside air, the ground or even water—a much more efficient process than generating heat from fuels—and they can be configured to work in homes with central ducts, radiators, or no heating distribution system at all.

They're also a great complement to an existing heating system: If you already have a newer furnace and aren't ready to replace it, you can opt for a hybrid setup that uses the (more efficient and more cost-effective) heat pump until outside temperatures falls below a set temperature.

Fully electrifying your space heating will require space on your electrical panel, so be sure to check out [Section 12](#) on Tips for avoiding an electrical panel upgrade. Also check out [Section 3](#) to learn about add-on thermal storage systems that can save you money and increase your resilience.

If you're thinking about replacing your heating or cooling system, consider a heat pump. The most energy efficient option available for heating and cooling, heat pumps offer so many additional advantages (see below) that you might wonder why they aren't more widely used already. But interest is growing rapidly.

WHAT IS A HEAT PUMP?

A heat pump is a remarkable piece of equipment that can heat and cool a home using very little energy. First invented in the mid-19th century, heat pumps use a refrigeration cycle to move heat from one location to another. It is a technology that we rely on every day to operate our fridges, freezers and air conditioners—but the heat pump that you install in your home can move heat in two directions. In winter, it pulls heat out of the air or ground outside and moves it into your home, while in summer, it takes heat from your home and moves it outside.

Because it uses energy to move heat rather than to generate heat, a heat pump can be many times more efficient than furnaces, boiler systems and electric baseboard heaters.

SPACE HEATING

HEAT PUMPS IN COLD CLIMATES

You may be wondering if a heat pump can handle our northern climate. The answer is yes: there are a range of heat pump technologies that are up for the task. Just look at Norway, where 60% of homes are heated with a heat pump **despite their cold climate**. Modern cold climate air source heat pumps (ccASHPs) are designed to operate efficiently down to temperatures as low as -30°C (-22°F), and an electric resistance heater can be added into the system to make up any shortfalls. Ground source heat pumps are another option—they'll operate efficiently regardless of the outside temperature because they extract heat from the ground, where temperatures are relatively steady over the year.

TYPES OF HEAT PUMPS

Air source heat pump (ASHP):

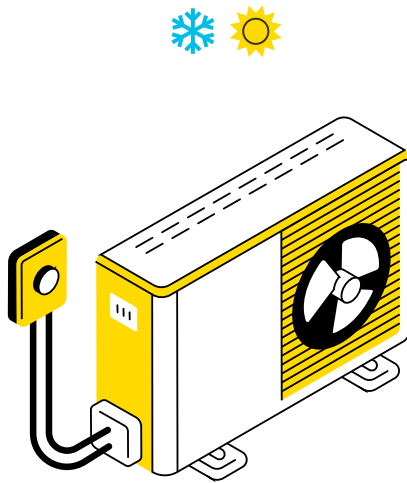

A conventional air source heat pump is the lowest cost option available and can provide all the heat needed in milder climates like Vancouver, or most of the heat needed in much of the rest of the country. ASHPs look like air conditioners—because they are air conditioners that also heat homes. They include an outdoor unit with coils, and a fan that exchanges heat with the surrounding air. To ensure functionality during very cold periods, ASHPs may require a built-in backup electric resistance heater, or they can be paired with an alternative heat source (e.g. hybrid heat pump).

Cold climate air source heat pump (ccASHP):

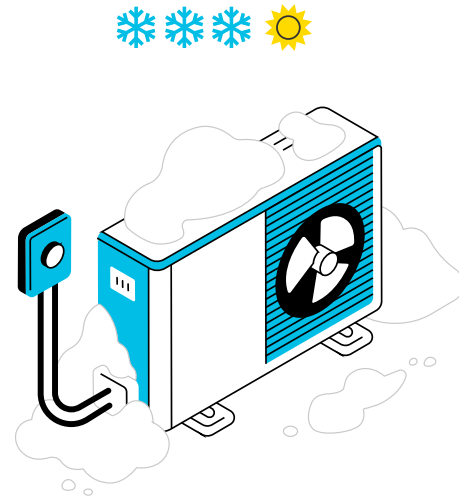

As the name implies, a cold climate air source heat pump is like a conventional ASHP, but designed to work efficiently and to move a lot of heat even at extremely low temperatures. The more complex design may result in higher upfront costs, but their high efficiency leads to operational savings. It is important for ccASHPs to be properly sized for your home to avoid over-reliance on built-in backup resistance heaters or alternative heating sources (i.e. hybrid model; [see our list of questions to ask installers](#)).

Hybrid heat pump (hybrid ASHP):

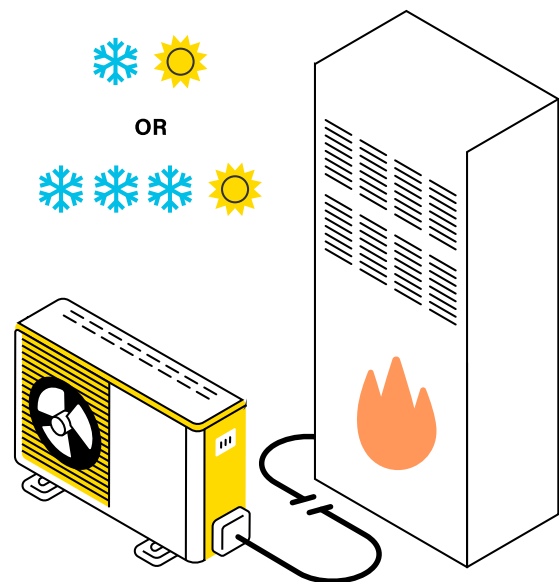

SPACE HEATING

Many air source heat pumps can be combined with a conventional fossil fuel heating system (such as a furnace), making it an appealing option if your home is already equipped with a newer heating system. These hybrids, also known as dual-fuel heat pumps, use the heat pump until outside temperatures drop below a set temperature, at which point the system switches to the fossil fuel heating system. To minimize your use of fossil fuels, ask that your heat pump be sized and programmed to optimize heat pump use for heating.

Ground source heat pump (GSHP):

Because ground temperatures are relatively stable over the year, GSHPs (sometimes referred to as geothermal or geoexchange heat pumps) are more efficient than ASHPs and can even provide some of a home's hot water via a "desuperheater". Instead of exchanging heat with the air through an outdoor unit, a GSHP uses underground loops to exchange heat with the ground. Horizontal GSHP loops are placed below the frost line and require sites with large open areas, whereas vertical GSHP loops

can be installed in most locations, but require special drilling equipment. GSHPs loops can also be placed in a body of water such as a lake or large pond. The ground loops are a long-term investment, as they can last 75 years or more, and the rest of the GSHP will last longer than ASHPs (20-25 years vs 15-20 years for ASHPs), as well as being far more energy efficient.

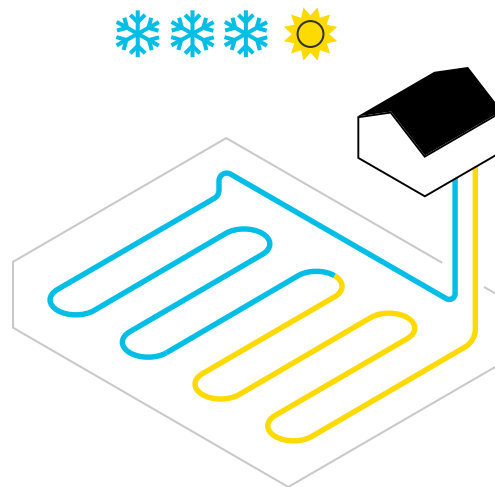

ELECTRIC RESISTANCE HEATING

Electric resistance heaters include electric baseboard heaters, electric furnaces and boilers, electric underfloor heating, and electric space heaters. These options typically cost far less to install than a heat pump, but they will cost more to operate because they are far less energy efficient. Some situations where electric resistance heating may be worth considering include:

As a supplemental heating source for spaces that are difficult to heat such as additions, basements, north-facing rooms, or garages.

For cottages or other buildings that are rarely used

in cold seasons—just be sure to consider how to prevent pipes from freezing.

As a backup to heat pumps without integrated resistance heaters. Ductless heat pumps often require separate backup heaters for very cold days.

When upfront costs are more important than operating costs. However, it is worth looking for heat pump incentives and financing options first to avoid paying more in operating costs or shouldering tenants with high energy costs.

OPTIONS FOR HEATING DISTRIBUTION SYSTEMS

Ducted systems:

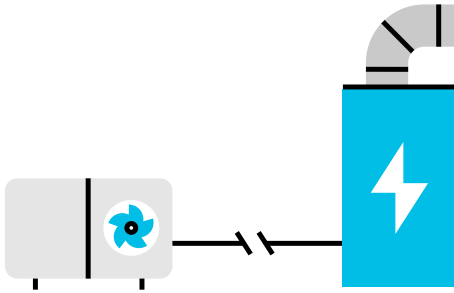

Most homes in Canada have forced air heating systems with ductwork. An ASHP or GSHP will use the existing ductwork and an air handler to circulate warm or cool air. It's important to ask your installer if the ductwork can accommodate the air flow of your desired heat pump, and what options are available if the ductwork is inadequate. Inadequate ductwork can lead to reduced efficiency and increased noise levels.

Ductless systems:

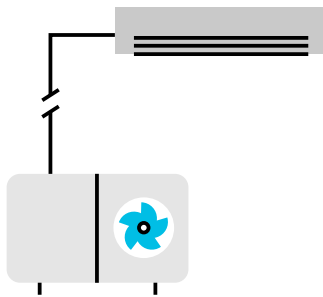

Homes without ductwork can use “mini-split” or “multi-split” heat pumps. These systems have wall- or ceiling-mounted units with a fan to distribute warmed or cooled air. The number of indoor units that a home will need depends on its size, layout, and number of rooms. Sometimes small duct systems are added to allow one indoor unit to serve multiple rooms (sometimes called a ducted mini-split), and one outdoor unit can serve one or several indoor units depending on the configuration. A notable advantage of this type of system is the ability to maintain different temperatures in various parts of your home.

Portable air source heat pump:

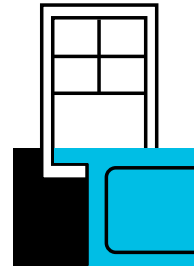

Small air source heat pump units with hoses that mount into a window opening are now available, much like existing portable air conditioners. Upcoming versions will include systems that hang like a saddle across a window ledge. These are less efficient than central and ducted systems, but they plug into a regular outlet and can effectively heat or cool a room.

Hydronic systems:

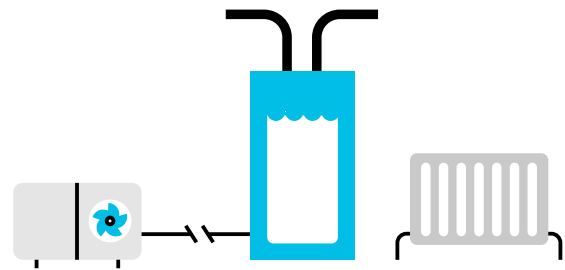

Homes equipped with boiler systems or radiant heating can use an air-to-water or ground-to-water heat pump system, which are already very common in Europe and are increasingly being installed in North America. The water circulating in these systems will be at a lower temperature than with a boiler, which may require upgrades to the radiators and the distribution systems. When these systems are used for cooling, pipe insulation and condensate drains may also be required. The hot water generated by the system can also be used.

SPACE HEATING



Electric heat pump features compared to gas equipment with separate air conditioning (AC):

Heat pumps are the most energy efficient way to provide heat.

Equipment	Outlet (amp requirements vary)	Upfront cost	Operating cost*	Emissions*
Gas furnace + AC	240V			
Gas boiler + AC	240V			
ASHP	240V	= / △	△	▼
ccASHP	240V	▲	△	▼
Hybrid ASHP	240V	= / ▲	△	▼
GSHP	240V	▲	▼	▼
Air to water HP	240V	▼ / ▲	=	▼
Portable ASHP	120V	▼	△	▼

*Updated April 2025, see appendix for breakdown of cost and emissions outcomes by province and territory

BENEFITS



In Canada we increasingly need heating and cooling solutions. Heat pumps provide both in one appliance.



Electric heat pumps produce no toxic carbon monoxide or climate-damaging carbon dioxide emissions, making them a safer option for homeowners and for the planet.



Heat pumps are the most energy efficient way to provide heat. Conventional fossil fuel heating systems convert the chemical energy in fuel to heat energy, and therefore cannot be more than 100% efficient. Because one unit of electrical energy can move many units of heat energy, heat pumps can be many times more efficient.



Heat pumps often cost less to operate than fossil fuel heating systems.^{2,3} Their efficiency more than makes up for the higher price of electricity in most regions.



By switching to an electric heat pump, you may be able to disconnect from the gas supply and save fixed connection fees. Just be sure to ask to have the meter removed and to have the gas account permanently closed.



Heat pump efficiency is characterized by two metrics: the seasonal energy efficiency ratio (SEER), which measures cooling performance during the summer months, and the heating system performance factor (HSPF) or seasonal coefficient of performance (SCOP), which evaluates heating efficiency in winter. An ASHP will have an SCOP of 2.08 to 3.87 (HSPF of 7.1 to 13.2), while a GSHP will have an SCOP of 3.2 to 5.0.⁴ For comparison, fueled furnaces and boilers have significantly worse SCOPs of 0.82 to 0.98.



Homes with heat pumps are more comfortable. While a furnace blasts hot air into the home then waits until temperatures fall below a set point before blasting heat

SPACE HEATING

again, a heat pump provides slow and steady heat. This results in less temperature fluctuations over the day. It also means that a heat pump will be more efficient if you leave the temperature consistent, even at night or when you are away during the day. As a result, the air, walls, floors and furniture will maintain a steady temperature without cooling off. This apparently subtle difference is one of the reasons why 81% of respondents to an international survey said they were more comfortable in their homes after installing a heat pump.⁵



Some hybrid heat pumps can be programmed to switch between heating systems to optimize operational costs based on outdoor conditions and utility costs.



A GSHP system will last longer than an ASHP system and most fossil fuel heating systems. Whereas ASHP will have a lifetime of 15-20 years, GSHPs generally have a life expectancy of 20-25 years,⁶ with the ground loops expected to last for 75 years or more.



A GSHP or an air-to-water heat pump may also provide some of a home's domestic hot water needs.

CHALLENGES

- **ccASHPs** and **GSHPs** have higher upfront costs than fossil fuel heating systems—but in most regions of Canada, they will have lower overall lifetime costs because they are less expensive to operate.
- **Heat pumps** provide slow and steady heat. This can take some getting used to, but most homeowners report being more comfortable in their homes after transitioning to a heat pump.

- For **ducted systems**, you'll need to ask your installer to check the airflow capacity of the ductwork, to avoid noise issues and reduced efficiency.
- With a **GSHP**, installers should estimate both the heating and cooling loads to ensure the heat withdrawn from the ground in winter is balanced by the heat added in summer.
- During a power outage, an electric heat pump will require more battery or backup generator power to operate than fueled heating systems. For safety reasons, even fueled heating systems such as gas furnaces will not operate during a power outage unless connected to a battery or generator.

OTHER CONSIDERATIONS

- By investing in major improvements to the building envelope (insulating, air-sealing and upgrading windows and doors), homeowners can install smaller, less expensive heat pump systems that cost less to operate while also improving home comfort.
- You may want to inquire about **heating-as-a-service options** for heat pumps, where a business pays for and owns all or part of the system and charges for the heating and cooling service.
- It can be worth checking online to see if local businesses or municipalities offer concierge services to help homeowners navigate home upgrades including electrification of heating.
- Heat pump systems can **be paired with systems that store heat during off-peak** times for use during peak hours (see [Section 3](#)). These can save homeowners money, and they are incentivized in many provinces and territories due to the benefits they provide to the electrical grid.

SPACE HEATING

- In some provinces (currently, BC, ON and QC), homeowners with heat pumps or air conditioners can sign up for **programs that offer incentives for reducing electricity use** during peak times. With such programs, the home will be pre-heated (winter) or pre-cooled (summer) in advance of a projected peak demand event so that the home can coast through the peak demand hours without using the heat pump or air conditioner. Ask your local utility if programs are available where you live.
- **ASHPs** and **ccASHPs** accumulate frost on the outside coils in winter. When this happens, a small amount of heat may be pulled from the home to melt the frost. Many heat pumps use a small resistance heater during this time to ensure occupant comfort. Also consider where this melted frost will drip and refreeze when choosing where to put the outside unit.
- The outdoor unit of an ASHP or ccASHP should be mounted off the ground in a location with good air flow.
- Just like furnaces, most heat pumps have air filters. Be sure to replace or clean these regularly. Check the manual for a schedule.
- Modern heat pumps are far quieter than older versions, but it's still advisable to position them away from patios and neighbours whenever possible. Wall-mounted heat pumps can be noisier due to vibrations.
- The outdoor unit of an ASHP or ccASHP should be kept clear of snow, vegetation and debris. Also, keep pets away from the units as their urine can cause corrosion in the coils.
- Installing a heat pump is more complex and can take longer than a fossil fuel heating system. It is best to have an experienced installer replace an older heating or cooling system before it fails.

WHAT ABOUT REFRIGERANTS?

Heat pumps use refrigerants for their operation, and occasional leaks of these substances may occur. Refrigerants can be very potent greenhouse gases, but their environmental impact is estimated to be lower than the impacts of natural gas leaks within homes. Furthermore, thanks to international agreements like the Kigali Amendment, manufacturers are moving towards low global warming potential (GWP) refrigerants.

To reduce the risk of refrigerant leaks, homeowners should work with an experienced and qualified heat pump installer ([see our list of questions to ask installers](#)).

HEAT PUMPS AND THE POWER GRID

In many parts of Canada, peak demand for electricity currently occurs during the hottest days, when air conditioners and heat pumps are in high use. As fuel heating systems are replaced with electric heat pumps, those peaks will likely shift to winter times. This has led to concerns about the power demand from heat pumps on cold winter days, and how it will impact the total generation capacity required by a province or territory.

While it is true that we will have to build more power generation capacity (including renewables plus storage), the peak winter demand may not be as high as many people anticipate. Heat pumps are more efficient than fuel heating systems, even at cold temperatures. Beyond that, there are other solutions to help mitigate these peaks, including GSHPs instead of ASHPs, home batteries, thermal storage systems, and EV chargers (for more information, see Sections [3](#), [9](#), and [10](#)). Improvements to building envelopes that reduce total heating loads will also reduce peak power demand.

Ultimately, utilities and energy regulators are paying close attention to concerns about increased demand, and plans are already underway to address them.

BUILDING ENVELOPE IMPROVEMENTS

Heat pumps and fossil fuel heating and cooling systems work with your building envelope to maintain a comfortable indoor temperature. The building envelope provides insulation and air sealing that prevent heat from moving out of your home in winter or into your home in summer. Improving the building envelope can involve adding insulation to the attic, exterior walls and/or foundation, sealing up air leaks, and upgrading windows and exterior doors. A heat recovery ventilator (HRV) or energy recovery ventilator (ERV) can be added to bring fresh air into your home with very little heat loss in winter or gain in summer.

Often, big improvements can be achieved with simple and low-cost measures such as sealing leaks around vent

pipes, replacing the weatherstripping around doors, or adding attic insulation. The greater the improvements to a building's envelope, the more energy and money you'll save, and the more comfortable your home is likely to be. Significant upgrades may even allow you to install a smaller (and less expensive) heating system.

If you are planning upgrades to the building envelope, it can be valuable to get a home energy audit done first. This personalized assessment can help you to identify the most effective strategies for improving the insulation and air quality of your home and can also identify potential concerns such as hidden moisture issues. Many home incentive programs will require a home energy audit before and after home improvements are made.

QUESTIONS FOR INSTALLERS

Investing in a new heating and cooling system can be intimidating. Knowing the right questions to ask can help you to make an informed decision when choosing a contractor and heating system for your home.

- How much experience do you have installing heat pumps/ccASHPs/GSHPs? Have your installers received manufacturer training to install these units?
- Can you give me references for similar installs and show me the qualifications of the installers who will do the work? Do you have worker's compensation insurance?
- Do you use load calculations to determine the size of heat pump needed? (See [Section 12](#) for more information on electrical loads)
- Do you assess the ductwork and air flow to determine if changes will be needed?
- Will I require any electrical or other upgrades to accommodate the heat pump system?
- Can I avoid an electrical panel upgrade with a historical load calculation, load share device or a smart electrical panel (see [Sections 12](#) and [13](#))?
- What is the total cost of the system, and the upfront deposit? What financing options do you offer?
- Are you aware of any incentives that I qualify for?
- Where will you install the outside unit?
- Where will you install the inside units (ductless)?
- For hybrid heat pumps, at what temperature will the system switch to the backup heater? Will you help me to program the system to maximize the use of the heat pump?
- Will you show me how to program and use the thermostat?
- How long will the install process take?
- What will you do to ensure that the system is set up and working properly?
- What do the warranties cover and how long do they last? If your company closes, who should I contact about warranties and replacements?
- How can I maintain and monitor the performance of the system?

NOTE: It is always a good idea to get multiple quotes from multiple installers before signing a contract.

CASE STUDY

Ground source heat pump:

Karen and Henry were finding that heating with oil was getting very expensive for their central Ontario home, built in 1875.

After a home energy audit and lots of research, they settled on a ground-source heat pump with a horizontal loop paired with an electric tank water heater that uses water pre-heated by the heat pump (desuperheater).

They are very happy with the switch, which is a long-term investment that will help to keep operating costs low well into their retirement years while reducing operational emissions by 94%.

More details can be found at [Green Communities Canada](#).



“

The geothermal heat pump is more consistent and gentler than the old oil furnace or air conditioner. I was afraid it wouldn't be warm enough for my mother-in-law, but it has been great.

–
Karen

Electric Thermal Storage at a glance

COST

Upfront costs:
\$\$\$-\$\$\$\$

Annual operating costs:
\$\$-\$\$\$

EFFICIENCY

100% or more

ELECTRICAL NEEDS

Varies by size and design

EQUIPMENT LIFESPAN

15-20 years

IMPLEMENTATION

Medium to difficult

EMISSIONS REDUCTION IMPACT

Varies by provincial electricity generation mix

BONUS

Opportunity to maximize use of low off-peak rates

3.

Electric Thermal Storage (ETS)

Thermal storage systems can be thought of as rechargeable batteries that store heat for later use. They can be charged using electricity during off-peak times so that the useful heat can be released during peak demand times.

In provinces with time-of-use or dynamic rates and

incentives for adoption, this can lead to savings on electricity bills. Tank water heaters are a common example of thermal storage devices, and thermal storage systems designed to work alongside heat pumps are becoming more readily available.growing rapidly.

WHY IS THERMAL STORAGE IMPORTANT?

Our provincial power systems always need to be able to provide enough electricity to meet demand. That means power system operators need to plan their generation capacity based on the highest electricity demand they expect to see—plus a buffer for good measure—even though that level of demand is only reached a few times a year.

Because it leads to generation capacity that goes unused for much of the year, building for peak demand results

in inefficiencies and increased costs. In most cases, it is more efficient and cost-effective to reduce the electricity demand during those rare peak demand events.

Thermal storage systems are a reliable way to reduce peak power demand in homes that have electrified their space and water heating. Many provinces and territories provide grants that cover most of the cost of installing thermal storage systems alongside heat pumps, because they are a cost-effective alternative to building out new generation capacity to meet peak power demand and stabilizing electricity prices.

ELECTRIC THERMAL STORAGE

OPTIONS

Thermal bricks are commonly used for electric thermal storage. Electric resistance heaters heat up high-density bricks in an insulated container when electricity prices are low. When electricity prices are high, air is blown over the bricks to pick up heat, which is then blown into the room. These can be installed as part of a central air system, or they can be installed as room units that look like panel radiators.

Phase change materials can be used for thermal storage. These systems take advantage of the heat that is absorbed by a material as it transitions from solid to liquid, which is then released when it changes back to a solid. Phase change materials can store more heat in a smaller area than thermal bricks and can store the heat almost indefinitely without losses. These systems can also be more energy efficient, since they can be “charged” using heat from a heat pump rather than a more energy-intensive electric resistance heater.

Some mini-split heat pumps use phase change thermal storage to reduce operating costs and minimize peak power demand. Phase change thermal storage systems can also heat water for use in hydronic space heaters (radiators) or to generate domestic hot water.

Water heaters are a form of thermal storage. If you have an electric tank water heater and use time-of-use pricing, it may be worth investing in a device that prioritizes recharging when rates are low. In addition, some utilities have “demand response” programs where a homeowner is offered incentives to allow the utility to shift the water heater’s electricity use to manage peak events, while ensuring hot water is available when needed. The water heater Section has more information on electric water heater options (see [Section 4](#)).

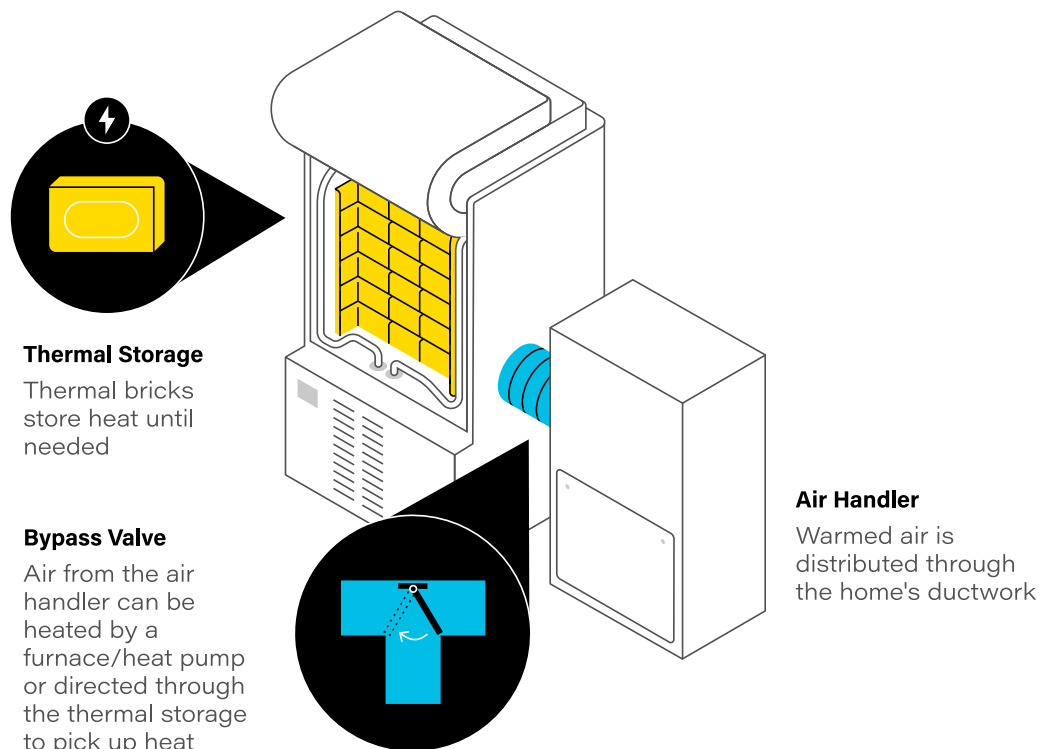

ELECTRIC THERMAL STORAGE

BENEFITS



ETS systems generate no toxic carbon monoxide or climate-altering carbon dioxide emissions.



In provinces where off-peak rates are many times lower than peak rates, operating a thermal storage system will reduce electricity bills, even compared to operating a heat pump.



Charging thermal storage during off-peaks hours can reduce carbon emissions. Off-peak electricity is typically generated from low-emission sources, while electricity from peak hours is more likely to include generation from fossil fuels.



ETS systems can also be charged up with zero-emission electricity from solar panels for use during times when solar power is not available and grid electricity is reliant on fossil fuels.



Thermal storage systems are quiet—you will typically only hear the fans running.



Thermal storage systems can be paired with other heating systems, such as electric heat pumps, or they can be used on their own as the primary heating source.



Thermal storage systems with thermal bricks are very simple systems with no moving parts. They do not require maintenance and are expected to last a long time.



During a power outage, an ETS system draws less energy from a battery or backup generator than a heat pump, since it only needs to operate the fan and release the stored heat. This can provide hours or even days of heat, depending how much heat is stored and how much is used.

CHALLENGES

- Thermal bricks and water heaters will lose heat to the surroundings over time. Thermal bricks are designed to release their heat within hours of being charged and are not suitable for storing heat over multiple days.
- Thermal storage units must typically be installed at the same time as a heat pump if they are being used together.
- Thermal bricks require additional space and are very heavy. Be sure to ask your installer if there is enough room for the unit you are considering.
- Thermal bricks are charged up using electric resistance heaters, which may require electrical upgrades to a home.
- Room units require adequate clearance and should not be obstructed by furniture or other items. Though they are well insulated, it is best to keep small children and pets away from the units.
- There are currently no thermal storage systems designed to cool homes in summer.
- Thermal storage systems with phase change materials are not yet widely available in Canada, although they are becoming popular in Europe.

OTHER CONSIDERATIONS

- Making large ice blocks in your freezer to cool your home might seem like a good idea, but it's counterproductive. The freezer pulls heat out of the water to make ice and expels it back in your home, which requires energy that generates additional indoor heat. Once the ice melts, your home may be slightly warmer than before.
- Do not store items or try to dry clothes on room units or thermal bricks.
- Some units come with smart technologies that can forecast the heat storage needed for the following day. If the stored heat falls short, the heat pump or the thermal storage system can be activated.

Water Heaters at a glance

COST

Upfront costs:
\$\$-\$\$\$

EQUIPMENT LIFESPAN

10-20 years

EMISSIONS REDUCTION IMPACT

High

ELECTRICAL NEEDS

120V 15-20amp
to 240V 20-30amp

IMPLEMENTATION

Medium to difficult

BONUS

Heat pump water heaters
are many times more
efficient than alternatives

Links to further resources:

- [Selecting a new water heater resource](#)
- [Natural Resources Canada water heater guide](#)
- [Heat pump water heater buyer's guide](#)

4.

Water Heaters

“

Taking a shower is awesome, it makes you feel nice and clean, makes you sound like a great singer, and helps you make all of life's decisions.

–

author unknown

Heating water for showers, laundry and other uses is the second largest use of energy in your home, and can also be the second largest source of emissions. For homes that use fossil fuels to heat water, switching to electric water heaters may be the simplest and most affordable way to make a significant reduction in your energy

use and GHG emissions. Even homes that already have electric water heaters can make improvements by adopting a heat pump water heater or solar water heater. As a bonus, electric tank and heat pump water heaters are ideal thermal batteries, using energy during off-peak hours to heat water for later use during peak hours.

WATER HEATERS

OPTIONS

Electric tank water heater:

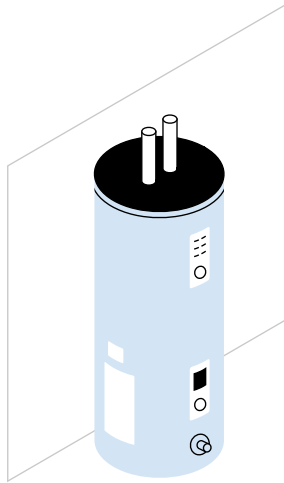

These water heaters have a large tank where water is heated and stored until you need it. They are more efficient than gas tank water heaters because virtually all the electrical energy goes to heating the water. If switching from a gas water heater, you may need an electrician to add a 240V 20-30 amp outlet for the heater. To avoid that upgrade, consider using a 120V heat pump water heater that plugs into a regular outlet—but be aware that 120V heat pump water heaters may not be available in all areas.

Electric tankless water heater:

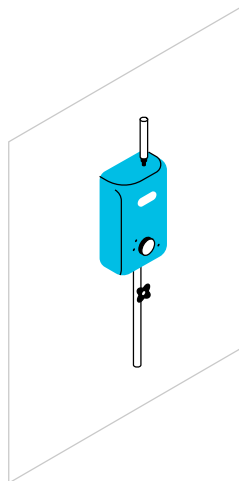

Tankless or on-demand water heaters use an electrical element to heat the water as you need it. They take up very little space and can be installed close to where the water is used, so your hot water doesn't have to travel long distances through cold pipes. They are also more efficient than electric tank water heaters because there is no heat loss during storage, and they may have longer lifespans in areas that do not have hard water. Electric tankless water heaters have lower flow rates than gas ones and will require a dedicated 30–60-amp 240V circuit.

Heat pump water heaters and hybrid heat pump water heaters:

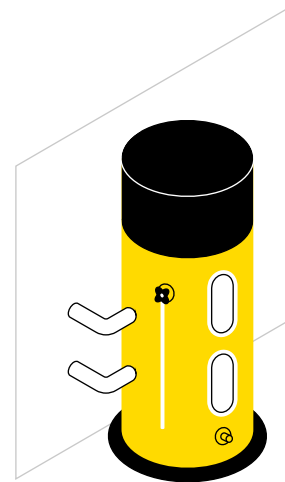

A heat pump water heater can be many times more efficient than a gas or electric tank or tankless system. Look for a larger capacity model than the water heater you are replacing to compensate for slower heating or be prepared for the backup resistance heater in a hybrid to engage if hot water demand is high. Heat pump water heaters pull heat from surrounding air to concentrate it in the water stored in the tank, and usually must be installed in heated indoor spaces with good air circulation, although an outdoor heat pump may be appropriate in milder climates. This does mean a slight increase in overall home heating to compensate for the heat used by the water heater in winter, but this is balanced by a decrease in home cooling in summer.

WATER HEATERS

Although most use a dedicated 30 amp 240V circuit, models are now available that plug into a regular 15 amp, 120V outlet—but these are best suited to homes with lower hot water demand, as they can take hours to recharge.

Solar water heaters:

You can heat your water using free energy from the sun with a solar collector and storage tank. The system can

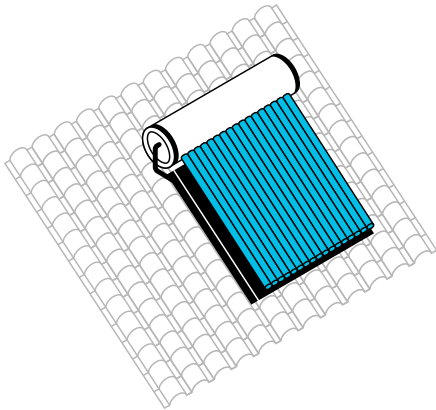

be very simple and reliant on passive movement of the heated water, or they may be more complex with fancy collectors and pumps to move water. In colder climates, fluids circulate between the collector and the water tank where the heat is transferred to the water in the tank using an exchanger. Because the sun doesn't always shine, these systems require an integrated backup water heater.

Ground source heat pump with a desuperheater:

If you are installing a ground source heat pump, ask about including a desuperheater. The desuperheater will very efficiently preheat your water using some of the heat extracted from the ground in winter or heat extracted from your home in summer. The heated water is then stored in a tank that will supply a regular water heater with pre-heated water, reducing the total energy needed.

ELECTRIC WATER HEATER FEATURES COMPARED TO GAS EQUIPMENT:

Equipment	Outlet (amp requirements vary)	Demand-response capable?	Upfront cost	Operating cost*	Emissions*
Gas tank WH	N/A	No			
Gas tankless WH	120V 15 amp	No			
Electric tank WH	240V 20-30 amp	Yes	▽	▲	▽
Electric tankless WH	240V 30-60 amp	No	=	▲	▽
Heat pump WH	240V 15-30 amp	Yes	▲	▽	▼
Heat pump WH	120V 15-20 amp	Yes	▲	△	▼
Solar WH	N/A	No	▲	=	▼
GSHP desuperheater	N/A	No	N/A	▽	▼

*Updated April 2025, see appendix for breakdown of cost and emissions outcomes by province and territory

WATER HEATERS

BENEFITS



Electric water heaters are safer than gas ones for people and the planet, because they do not generate any hazardous carbon monoxide or climate-damaging carbon dioxide during operation.



Unlike gas water heaters, electric ones do not require a venting system. Sealing up the gas vent after installing an electric water heater is another way to reduce air leaks and heat loss from your home.



Some electric tank water heaters can be programmed to take advantage of lower time-of-use electricity rates or electricity generated from onsite solar arrays.



Many electric tank water heaters have built-in technology that allows them to act as a thermal battery and participate in utility demand response programs. When enabled by the homeowner, water heaters are programmed to provide hot water as needed, but the utility can control when it does the heating. The utility pays the homeowner for this access, which helps manage grid-scale peak power demands and respond to grid destabilization events.



A tankless water heater may be the best option when working in small spaces. Some will even fit under the counter.



Heat pump water heaters will help to cool and dehumidify your home in summer as they pull heat and humidity from the air. The water extracted from the air will be pumped to a drain or empty into the drain by gravity.

CHALLENGES

- It is important to properly size water heaters to ensure you always have hot water when needed. For tankless water heaters, have your installer estimate the maximum volume of hot water needed per minute in your home to ensure the system can meet your needs. For heat pump water heaters, consider using a larger tank to compensate for slower heating, and using a higher tank temperature with a mixing valve that mixes in cooler water to prevent scalding.
- Tankless water heaters require more electrical panel capacity than other electric alternatives and are discouraged in some jurisdictions for this reason. Consider future electrification plans, panel capacity, and local requirements when choosing an electric water heater.
- 120V heat pump water heaters take extra time to recharge and are best used in homes where hot water demand is minimal or spread out over the day.
- With a heat pump water heater, there will be a small heating penalty in winter because the space heating system must replace the heat that the water heater extracts from the air.
- A heat pump water heater must be carefully sited. The room must be at least 100 sq ft with good ventilation to allow it to extract enough heat from the surrounding air, and it should ideally be separate from living spaces as the compressor will make more noise than a conventional water heater (though most are still pretty quiet). For most of Canada, situating the heat pump outside is not an option because of the cold winters.
- Electric water heaters will not heat water during a power outage (and neither will high efficiency gas water heaters), but you will continue to enjoy hot water without electricity until the hot water in your tank is used up.

WATER HEATERS

OTHER CONSIDERATIONS

- Water heater efficiency is reported as uniform energy factor (UEF, similar to COP), with typical gas and electric tank water heaters having a UEF of 0.63 to 0.95. Heat pump water heaters have a higher efficiency with UEF values of 2.3 to 3.3 or more. ENERGY STAR models are among the most efficient.
- Replacing the anode rod that protects the tank from corrosion every 3-4 years can extend the life of a tank water heater.
- Tankless water heaters will have shorter lifespans in areas with hard water. To increase their lifespan, be sure to flush out any mineral deposits regularly.
- Heat pump water heater air filters should be cleaned regularly. Check the manual for a schedule.
- A leak detection system can be added and will alert you to leaks and shut off the water supply to protect your home from water damage if the tank fails.
- To avoid interruptions, consider replacing a water heater before it fails. Most tank water heaters last for 10-15 years.
- It is generally lower cost overall to buy a water heater instead of renting, but buyers don't enjoy the benefits of servicing if issues arise.
- If you are going away for an extended period, save money by programming your water heater to shut off until shortly before your return.
- Add a mixing valve to your water heater to protect your health and safety. With a mixing valve, you can set your water heater temperature high enough to prevent the growth of harmful bacteria (60°C, 140°F) while ensuring water leaving the tank is cooled enough to prevent scalding (49°C, 120°F).
- You can save money and install a smaller water heater tank if you reduce your hot water use. Tips for reducing hot water use include:
 - » Install low-flow showerheads and faucets
 - » Choose efficient appliances such as washing machines and dishwashers
 - » Wash clothes in cold water
 - » Fix water leaks
 - » Insulate hot water pipes
 - » Set your tank's thermostat at 60°C (140°F) and use a mixing valve

QUESTIONS FOR INSTALLERS

- Which model and size do you recommend for my household?
 - Will any electrical panel and/or wiring upgrades be needed? Are there options for avoiding an electrical panel upgrade? Will the cost of this electrical work be included in your estimate?
 - Will you be installing a mixing valve?
 - Do I qualify for any incentives?
 - What is the warranty?
- If it is a heat pump water heater:
- How many heat pump water heaters have you installed?
 - Where will the condensate drain go?
 - Will there be enough air circulation to supply the heat pump water heater?
 - How do I operate the heat pump water heater to maximize energy savings?
 - How do you size the heat pump water heater?
 - Will I require any electrical upgrade and if so, are they included in your quote?

CASE STUDY

Building envelope upgrade:

Tim and his family really wanted their new home to be comfortable and energy efficient.

Built in 1971, their Vancouver home was due for upgrades. During the pandemic, Tim and family added insulation to the walls, put in new windows, improved the air sealing, replaced the exterior siding, and installed a metal roof.

A new heat pump and heat pump water heater rounded out the deep energy efficiency upgrade. Their new home looks modern and is far more comfortable, especially on hot days.

More details can be found at [Green Communities Canada](#).



“

Right now, even though we're in a spring heatwave, our heat pump will go on the cooling cycle for an hour or two and it will keep the whole house cool for the rest of the day because our home is so well-insulated, and its building envelope is so tight and efficient

—
Tim

Cooking at a glance

COST

Upfront costs:
\$\$-\$\$\$

EQUIPMENT LIFESPAN

10-15 years

RENTERS

Consider a portable
induction cooker

ELECTRICAL NEEDS

240V 40-50 amp

(two outlets if cooktop
and oven are separate)

IMPLEMENTATION

Easy to difficult

BONUS

Improved indoor air
quality when replacing gas

EMISSIONS REDUCTION IMPACT

Medium to high

Better cooking experience
with induction

Links to further resources

- [Natural Resources Canada Cooking Appliances website](#)

5.

Cooking

“

I love our big induction range—I'd never go back to gas.

—

James Ramsden of Michelin-starred East London Restaurant Pidgin.⁸

More and more people are switching to induction ranges and cooktops because they provide fast and controlled heating with easy cleanup and no combustion gases.

Gas stoves are a significant source of indoor air pollutants such as nitrogen oxides (NO₂, NO), carbon monoxide (CO), and fine particulate matter (PM2.5).

Pollutants from stoves are bad for climate change and can increase

the risk of asthma and other illnesses, with children being particularly susceptible.⁹ The open flame of a gas stove is also a fire hazard that can be avoided when switching to cooking with electricity.

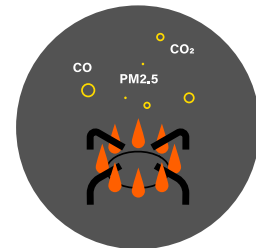

COOKING

OPTIONS

Coil cooktops and ranges:

These are traditional electric ranges coil elements. They are simple and easy to use.

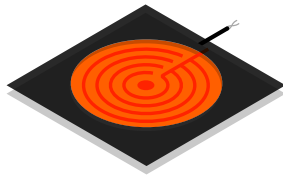
Ceramic cooktops and ranges (aka radiant or glass cooktop):

These use an electric coil that is covered by a ceramic or glass surface, making it easy to clean.

Induction cooktop:

Electromagnets under a glass surface induce a small current in the cookware, causing them to heat up directly. Cooking with induction is faster, allowing for instant temperature control and fast clean up.

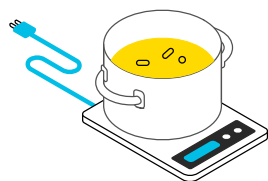
Portable induction cookers:

Single element induction cookers are cost-effective options that plug into regular kitchen outlets. Although

less powerful, they still offer the benefits of cooking with induction without the large investment in a new appliance and are a great option for renters.

Conventional electric oven: These ovens have a broil element at the top and a baking element at the bottom of the oven. They are simple and easy to use.

Convection oven: These are conventional ovens with an added fan that circulates hot air through the oven. They allow for faster and more even cooking.

BENEFITS



Cooking with gas generates combustion gases and fine particulate matter that is bad for your health (see above). Even when a gas range is turned off, it may be releasing air pollutants through gas leaks. Any of the electric options listed here will result in better indoor air quality and reduced health risks.



Induction is by far the fastest and most efficient way to cook food because these cookstoves heat the pot directly. Electric coils are also faster than gas, but ceramic cookers take longer than electric coils due to the extra layer of ceramic to heat.



Induction and radiant cooktops have a ceramic or glass top that is easier to clean than a gas or electric coil element.



Gas stoves put out a lot of heat, most of which ends up in your kitchen, not your food. Electric stoves, and especially induction stoves are better at directing the heat to your food. Induction stoves are so good at heating just the pot and the food that the stove surface can be cleaned right after cooking!



Induction provides instant temperature control with multiple settings.

COOKING

COOKTOP, RANGE AND OVEN FEATURES COMPARED TO GAS EQUIPMENT:

Equipment	Outlet	Time to boil water	Upfront cost	Operating cost*	Emissions*
Gas cooktop or range	120V 15-20 amp				
Electric coil cooktop or range	240V 40-50 amp	faster	▽	△	▽
Radiant cooktop or range	240V 40-50 amp	faster	=	△	▽
Induction cooktop or range	240V 30-50 amp	Much faster	△	△	▽
Electric conventional oven	240V 20-50 amp	N/A	△	△	▽
Electric convection oven	240V 20-50 amp	N/A	△	△	▽

*Updated April 2025, see appendix for breakdown of cost and emissions outcomes by province and territory

CHALLENGES

- Induction cooktops will only work with cookware that is magnetic—if a fridge magnet sticks to the bottom, you are good to go. You can also buy a heat diffuser or induction adapter plate that transfers heat to your favourite cookware if it is not compatible. Ovens and coil or radiant cooktops will use the same cookware that you use with your gas appliances.
- Induction cooktops can make a buzzing or humming sound during normal operation. The sound may decrease with a different pot, with lower temperature settings, and with higher quality induction cookers.
- Electric cooking appliances will not function during a power outage unless they are connected to a battery or generator.
- Concerns have been raised about the potential for the electromagnets in induction cookers to interfere with pacemakers or defibrillators. Recent studies¹⁰ have shown that the effects on these devices are within the recommended limits unless a person is very close to an active element (e.g. leaning directly over the pot). Persons with these devices are advised to choose coil or radiant cooktops or to keep the induction burners at arm's length when cooking.

OTHER CONSIDERATIONS

- You may need an electrician to add a new 240V, 40-50amp outlet if your home is switching from gas cooking appliances to electric. A range that combines the cooktop with the oven may be a better option as this will require only one high voltage outlet and one breaker on the electrical panel. For a small household, you may be able to avoid these large appliances altogether by using several single element induction cookers, a microwave, and a larger toaster oven.
- Range hoods are used to extract harmful indoor air pollutants generated by burning fuels for cooking but also from cooking the food itself. This is why range hoods are still recommended with electric and induction stoves.
- Using a smaller and simpler appliance to cook small meals or reheat food can save energy—microwaves, electric kettles, and toaster ovens are great examples. Some ovens include a removable divider that allows you to use just half of the oven at a time. Microwaves, electric kettles, and toaster ovens are great examples. A pressure cooker will also cook food faster and with less energy.

CASE STUDY

Cooking with induction:

When his air purifier kept showing poor indoor air quality whenever their gas stove was in use, Colin and his family knew it was time to try something different.

Replacing the stove wasn't an option in their Vancouver condo, so they bought a single induction cooker that plugs into a regular outlet. Right away they noticed that cooking was faster and easier than with gas, and the kitchen didn't heat up as much in the summertime.

The indoor air quality improved too, and the lack of open flames means Colin feels safe letting his 12-year-old daughter experiment with cooking on her own.

Today that single element induction cooker is used for 90% of their cooking.



“

**The induction
cooker has been
really great!**

—
Colin

Dryers at a glance

COST

Upfront costs:
\$\$-\$\$\$

IMPLEMENTATION

Easy to difficult

RENTERS

Consider a ventless dryer

ELECTRICAL NEEDS

120-240V and 15-30 amp

EMISSIONS REDUCTION IMPACT

Medium

BONUS

Some electric dryers are
ventless

EQUIPMENT LIFESPAN

10-13 years

Links to further resources

- [Consumer Reports](#)
- [List of EnergyStar dryers](#)

6.

Dryers

“

Wouldn't it be great if we could put ourselves in the dryer for a short time and come out wrinkle free and two sizes smaller?

–

author unknown

Dryers use a lot of energy to remove the water from your clothes, which is why most electric dryers use a heavy duty 240V outlet. Fortunately, there are increasingly options available that plug into the same 120V outlet that a gas dryer uses. Condensing and heat pump dryers that do not require a vent to the outside are common in Europe and

are now available in North America. Even better are the combo washer and dryers that do it all in one without your having to move your clothes. The best is when you can hang your clothes outside to dry in the fresh air.

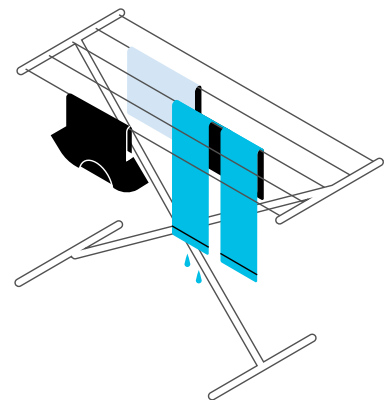

DRYERS

OPTIONS

Electric dryers:

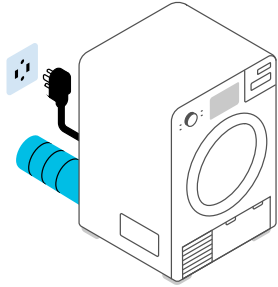

These dryers use electric resistance heaters to dry your clothes and require a vent to the outside to get rid of warm, moist air.

Condensing dryers:

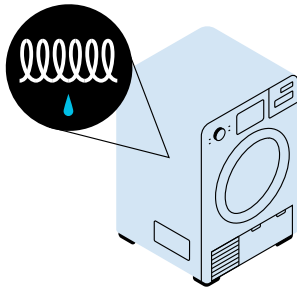

Condensing dryers use electric resistance heaters for drying, but instead of a vent to the outside they have a separate cooling element that acts like a dehumidifier to condense the water from the moist air, collecting it in a pan or sending it down a drain. They are more efficient than electric dryers and are handy when venting to the outside is not an option.

Heat pump dryers:

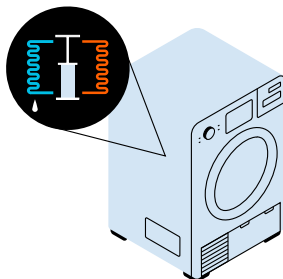

These dryers use a heat pump refrigeration cycle that moves heat. In this case they move heat into the air entering the dryer drum and pull heat from the air that exits the dryer drum to condense out the water into a drain or pan. That same air is then reheated before returning to the dryer drum. Think of it as a very efficient way of moving water from your clothes to the drain.

120V electric dryers:

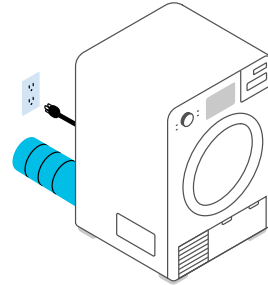

Electric dryers that plug into the same conventional 120V outlet that gas dryers use. They are often condensing and/or compact models.

Combined washer-dryers:

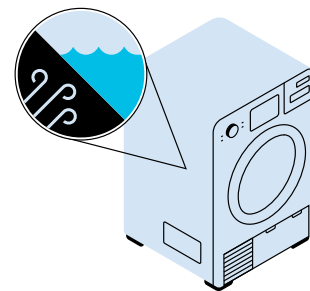

Wash and dry your clothes in one go with one appliance. These use condensing technologies and will run on 120V.

DRYERS

BENEFITS



Electric dryers are safer than gas ones, for both people and planet, because they do not generate any hazardous carbon monoxide or climate-damaging carbon dioxide emissions during operation.



Unlike gas dryers, electric heat pump and condensing dryers do not require a vent to the outside. Sealing up the vent after installing a heat pump or condensing dryer is another way to reduce air leaks and heat loss from your home.



All electric dryer options use lower temperatures than gas ones, which is less harmful to fabrics, helping your clothes to last longer, but it does take longer to dry the clothes.



Condensing and heat pump dryers use far less energy because they recycle the warm air to continue drying after condensing out the water rather than venting it to the outside.



Condensing and heat pump dryers do not require a vent to the outside, so they are ideal when installing a dryer far from an outside wall or when adding a vent is not an option.



Condensing dryers are now available that can plug into a conventional 120V outlet. That means you can install one anywhere and it will leave space on your electrical panel for other electrification upgrades.



Combined washer-dryers mean no moving laundry from one appliance to the next: just add your clothes, choose your settings, and return later to clean, dry laundry.

DRYER FEATURES COMPARED TO GAS DRYERS:

Equipment	Outlet	Drying time	Capacity	Ventless option	Upfront cost	Operating cost*	Emissions*
Gas	120V 15 amp			N			
Electric	240V 30 amp	=	=	N	=	▲	▼
Condensing	240V 30 amp	△	▼/=	Y	△	▲	▼
Heat pump	240V 30 amp	▲	▼	Y	△	▲	▼
120V condensing	120V 15-20 amp	▲	▼/=	Y	△	▲	▼
Combined	120V 15-20 amp	▲	▼	Y	▲	▲	▼

*Updated April 2025, see appendix for breakdown of cost and emissions outcomes by province and territory

DRYERS

CHALLENGES

- Check your dryer outlet before shopping for a dryer. You will want to make sure the plugs are compatible. If you are switching from a gas dryer to an electric one, you can have an electrician install a 240V outlet or choose one of many options that use 120V.
- Drying times can be much longer with condensing and heat pump dryers because they use lower temperatures that will also prolong the life of your fabrics.
- Condensing and heat pump dryers often have smaller capacities. With these you may have to run smaller laundry loads or hang dry some items.
- There can be more humidity around ventless dryers. If your dryer has a collection pan rather than emptying directly into the drain, be sure to empty the pan regularly and ensure air can circulate around the dryer.

OTHER CONSIDERATIONS

- Line drying is the most energy efficient way to dry your clothes and you can get that lovely “dried outside” scent.
- Using a high-speed spin cycle on the washing load will mean less water for the dryer to remove.
- Use the sensor setting instead of the timer to avoid wasting energy.
- Lint trapped in vents is a fire hazard and reduces appliance efficiency. Be sure to clean the lint trap after every load and clean the dryer vent pipe every 3-6 months (e.g. by disconnecting the vent pipe from the dryer and vacuuming from both ends).
- Dryers come in different sizes, always measure your space before shopping for a replacement.



Benefits of ventless dryers



Use far less energy



Can be installed anywhere



Lower temps are more gentler on fabrics



Reduce air leaks and heat loss from your home

Fireplaces at a glance

COST

Upfront costs:
\$\$-\$\$\$

IMPLEMENTATION

Easy to medium

BONUS

Improved indoor air
quality and safety when
replacing gas

ELECTRICAL NEEDS

120V 15 amp

(some exceptions)

EMISSIONS REDUCTION IMPACT

Low to medium

EQUIPMENT LIFESPAN

10-20 years

7.

Fireplaces

“

We no longer build fireplaces for physical warmth, we build them for the warmth of the soul; we build them to dream by, to hope by, to home by.

—
Edna Ferber

If you are looking for a fireplace to dream, hope and home by, consider these electric options. They provide the cozy warmth and ambiance of a fire without the safety concerns that come with open flames, carbon monoxide, and other combustion byproducts. Modern versions allow for adjustable flame colours and brightness and look just like the real thing.

OPTIONS

Electric fireplace:

They use electric resistance heaters to generate heat. The illusion of dancing flames is generated using light reflection or a video display. These can fit in an existing fireplace, be mounted in or on a wall, or be free-standing.

Water vapour fireplace:

These fireplaces also generate heat with an electric resistance element, and they use ultrasound to break water into fine water vapour, making a fine mist that is lit up by LED lights creating a realistic illusion of fire. Water may be supplied by a tank that is refilled or the system may be connected to your home's plumbing.

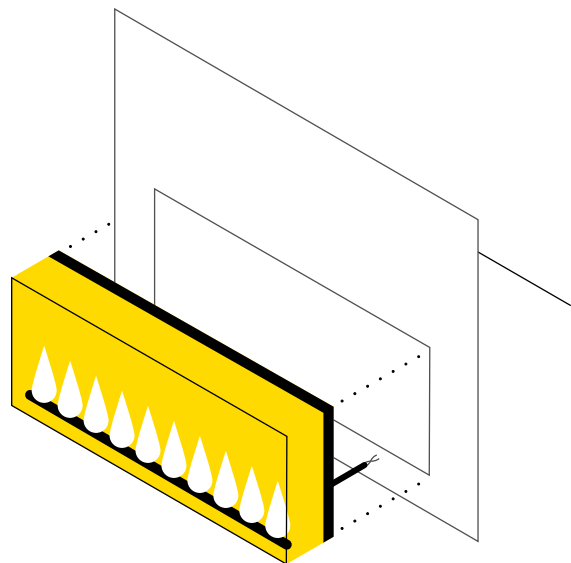

FIREPLACES

ELECTRIC FIREPLACE FEATURES COMPARED TO GAS FIREPLACES:

Equipment	Outlet	Upfront cost	Operating cost*	Emissions*
Electric fireplace	120V 15 amp or higher	▼	△	▼
Water vapour fireplace	120V 15 amp	=	△	▼

*Updated April 2025, see appendix for breakdown of cost and emissions outcomes by province and territory

BENEFITS



Unlike wood or gas fireplaces, electric ones do not produce any soot, smoke, carbon monoxide or other combustion gases that can have health risks and reduce indoor air quality.



There are no open flames with an electrical fireplace and no opportunities for gas leaks or carbon monoxide poisoning, making them a safer option. Electric fireplaces will still get hot enough to cause burns, so be sure to keep young children away from the unit.



In most cases, these can be installed by a homeowner and plug into a standard electrical outlet.



In most provinces, the electricity used to power an electric fireplace will generate fewer GHG emissions than a gas fireplace will.



Since there is no smoke or other combustion products from an electric fire, you can seal up your chimney (either temporarily or permanently) and further reduce home air leaks.

CHALLENGES

- Electric fireplaces will not operate during a power outage unless connected to a battery.
- Some people find the artificial flames to be less realistic. It is advisable to explore various brands and compare flame effects. In general, higher priced models have more realistic flames.
- Depending on the size, an electric fireplace may not put out as much heat as a gas version.
- Water vapour fireplaces can increase the humidity of your home and may require filling a tank with water.

Outdoor Equipment at a glance

COST

Upfront costs:
\$\$-\$\$\$

IMPLEMENTATION

Easy

RENTERS

Electric BBQs may be a good option for balconies

EQUIPMENT LIFESPAN

5-10 years (5 years for batteries)

EMISSIONS REDUCTION IMPACT

Low to medium

BONUS

Quieter and pollution-free operation

For more information

- [Fact sheet on protecting hearing during yard maintenance](#)
- [Article on lawn care hazards to health and the environment](#)
- [Report on the health and environmental case for electric lawn care](#)

8.

Outdoor Equipment

Yard Maintenance Equipment

“

I don't need a gym membership; I have a lawnmower.

–

Author unknown

OPTIONS

Corded equipment:

These draw electricity from an outdoor outlet through an extension cord. You can find corded lawnmowers, trimmers, leaf blowers, hedge trimmers, chainsaws, rototillers and more.

Battery powered equipment:

These have removable battery packs that you can charge between use. Look for battery-powered lawnmowers, trimmers, leaf blowers, hedge trimmers, chainsaws, rototillers and more. Most battery packs are designed so that they can be used in multiple pieces of equipment from the same manufacturer.

Ride-on battery lawnmowers are also available.

If you have a yard, chances are that you own at least a **lawnmower**, and possibly also a trimmer, leaf blower, hedge trimmer, chainsaw, or rototiller. Gas lawnmowers are used by 75% of Canadian households who cut their own lawns,¹¹ but they are not always ideal. Gas yard care tools are the noisy, dirty and messy options compared to the electric versions available.

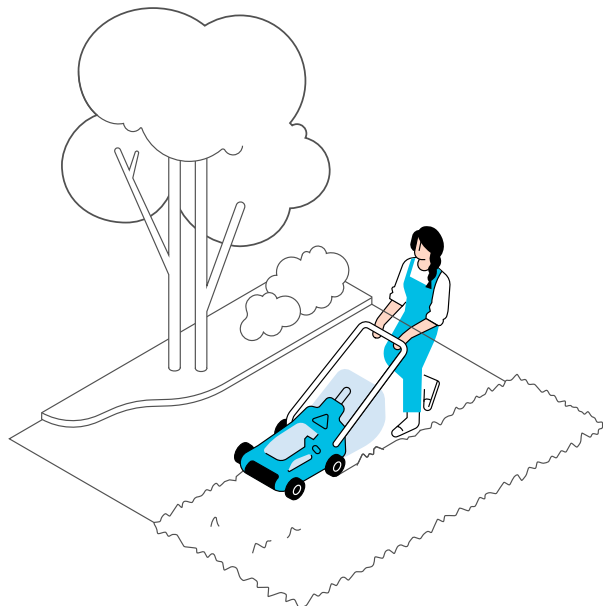

OUTDOOR EQUIPMENT

BENEFITS



Electric yard equipment is significantly quieter than their gas counterparts. Ear protection is recommended whenever yard equipment is used, and this is particularly important for gas equipment. Some jurisdictions in Canada already have time-of-use restrictions for some yard equipment due to noise concerns.¹²



Electric yard equipment generates no air pollution, while gas yard equipment has no pollution control and produces noxious fumes including carbon dioxide, fine particulate matter, nitrogen oxides and the volatile organic compounds that cause smog. A US study showed that one hour of cutting grass with a commercial lawnmower is equivalent to nearly 500km of driving when it comes to smog-forming pollution.¹³



Electric yard equipment is largely maintenance-free and does not require seasonal fuel changes. Just remember to store your batteries inside during the hottest and coldest weather to prolong their life.



Electric equipment is typically lighter, making it easier to use, maneuver and store.



Electric equipment is also safer to store because there are no flammable liquids involved.



The batteries from battery powered equipment can be used in multiple tools. If you buy from the same manufacturer, you can use the same batteries for all your yard care equipment. Package deals may also be available.

CHALLENGES

- Corded equipment requires a convenient outdoor outlet, which means a limited range, and can take some getting used to.
- Battery equipment must be charged between use and may not have enough capacity for large yards.
- The batteries used in yard equipment will last longer if stored in a conditioned space, especially during hot and cold weather.
- Electric lawnmowers may not be as powerful as gas equivalents, meaning two passes may be required when the grass is tall or wet.

OTHER CONSIDERATIONS

- There are human-powered options available for most electric yard maintenance equipment. They are cheaper, quieter, easier to maintain, and they give you a free workout at the same time!
- Consider the size and configuration of your yard. If you have a large yard or one with multiple trees that could entangle electric cords, battery options may be preferable.
- Check the battery size and estimated run time to make sure you can cut your entire lawn in one charge.
- Batteries will generally last longer if they are stored partially or fully charged. Overcharging will also shorten a battery's life so unless the manual says otherwise, you should not store it on the charger.
- Batteries will likely fail before the equipment fails. Be sure to recycle the old battery when buying a replacement.

OUTDOOR EQUIPMENT

Snowblowers

What would Canada be without snow?

While a fresh snowfall can make everything look sparkly clean, the process of cleaning driveways and sidewalks is far less pleasant. Many homeowners own or would like to own a snowblower to make that work easier.

Electric snowblowers may be the answer. In general, these are lighter, quieter, smaller, and easier to maintain, but less powerful than their gas-powered counterparts. Electric snowblowers come in corded and battery versions where the battery can often be used in other compatible electric yard equipment.

If you mostly deal with light snow and small areas, a **power snow shovel** or a **single stage electric snowblower** may be the way to go.

If you regularly clear deep or wet snow, then you should be looking for a **higher end two-stage battery electric snowblower**.



Pool Heaters

If you have a pool, then you will want to enjoy it for as much of the year as you can. That is why you may want to add a pool heater.

Solar water heaters combined with an insulated pool cover are popular because they are the simplest, lowest-cost option but they are dependent on good sun exposure, and it can take time for them to raise the temperature of the water.

Electric resistance pool heaters are easy to install and are a good option for smaller pools.

If you are willing to spend more, consider a **heat pump pool heater** that can move heat into your pool incredibly efficiently, and works well right down to air temperatures of 10°C (50°F).

BBQ

Even barbeques can be electrified. Not only are they good for households looking for a safer cooking experience, but they are also ideal for balconies where conventional barbecues may not be allowed.

Electric barbecues provide more precise temperature control, can be safely used indoors, and require very little maintenance. In most provinces, cooking with an electric BBQ will also reduce your GHG emissions. First, check that there is a convenient outlet to plug in your barbecue, and then shop around to find a unit that suits your needs. Wood burning pellets are available to give your cooking that authentic BBQ flavour.



CASE STUDY

Electric snow shovel:

Cathy invested in an electric snow shovel just before a heavy snowstorm in Kitchener, Ontario last winter.

She found it a huge improvement over using a shovel and a great alternative to the heavy gas-powered snowblowers that she couldn't maneuver on her own.

As a bonus, the battery-powered snow shovel fits in her front hall closet, has no cord to run over, and has no smelly gas to mix and store.



“

Clearing snow with my electric snow shovel is easy-peasy!

—
Cathy

EV Chargers at a glance

COST

Upfront costs:
\$-\$\$\$\$

IMPLEMENTATION

Easy to difficult

RENTERS

Talk to your property owner about EV charging

CHARGING SPEED

10-13 years

EMISSIONS REDUCTION IMPACT

Very high

CHECK

The connector type and charging power

ELECTRICAL NEEDS

120V 15 amp to 240V 100 amp

BONUS

Power appliances or your home during a power outage with EVs capable of V2L, V2H or V2G

Links to further resources

- [Guide to home EV charging](#)
- [Vehicle-to-load Explained](#)

9.

EV Chargers

“

You have to have a better car. It's not just the ideological decision of buying an EV. It's about buying a better car.

–

author unknown

The easiest way to keep an electric vehicle (EV) charged up and ready to go is by using a home charging station. This is also the lowest cost option, especially when owners can take advantage of low time-of-use rates available in some provinces.

North American EVs can have a variety of connectors for charging. Most new vehicles

come with a NACS (North America Charging Standard, also known as SAE J3400) connector that is used for level 1, 2 or 3 charging.

Some vehicles will have an SAE J1772 connector for level 1 or 2 charging and a second connector for level 3 fast charging. The second connector will be either CCS or CHAdeMO.



J1772



CCS



Chademo



Tesla/NACS

EV CHARGERS

OPTIONS

Level 1:

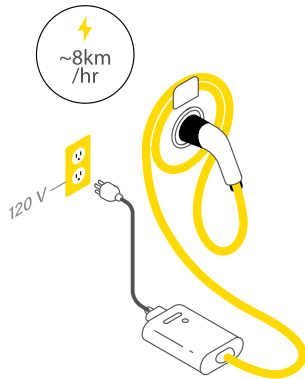

You absolutely can charge your EV or plug-in hybrid using your portable EV charging cord plugged into a standard household outlet. You can charge your car just about anywhere with an electrical outlet. This is the slowest speed of charging, achieving approximately 8 km of driving range for every hour of charging, but it is also ridiculously cheap relative to gasoline or public charging. With overnight charging letting you drive more than 60 km, this may be all you need.

Level 2:

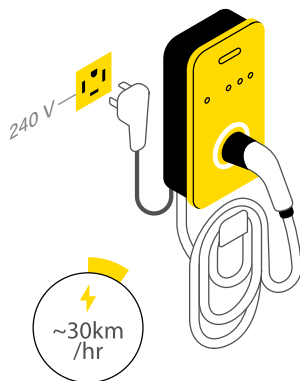

For speed and convenience, you may want to invest in a level 2 home charger. These chargers can be hard-wired into your home or use a 240V outlet. Once it is there, you can get an average of 30 km of driving range for every hour of charging at very low cost. Level 2 chargers come with different power outputs (in amp ratings), and

some allow you to set the power output. In general, the higher the power output, the faster the charge, but not all EVs can benefit from higher power outputs, and lower power systems leave electrical panel space for other electrification projects.

Level 3:

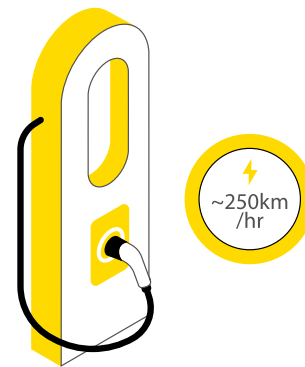

For fast charging while on the go, look for public level 3 chargers. These are not suitable for home installs because they require very high amperage to supply the power needed.

EV CHARGERS

EV CHARGER FEATURES

Equipment	Purpose	Charging speed	Outlet	Upfront cost	Operating cost	Emissions
Level 1 charging cable	Charging EV	~8 km/hr	120V 15 amp	Up to \$\$	▼	▼
Level 2 charger	Charging EV	~30 km/hr	240V 20-60 amp	\$\$	▼	▼
Bidirectional charger	Charging EV/ vehicle to grid	~30 km/hr	240V 20-100 amp	\$\$\$-\$\$\$\$	▼	▼
Vehicle to load	Powering appliances	N/A	none		N/A	▼
Vehicle to home (vehicle to load)	Powering a home	N/A	Manual transfer switch	\$\$-\$\$\$	N/A	▼

*Updated April 2025, see appendix for breakdown of cost and emissions outcomes by province and territory

Bidirectional charger for vehicle-to-grid (V2G):

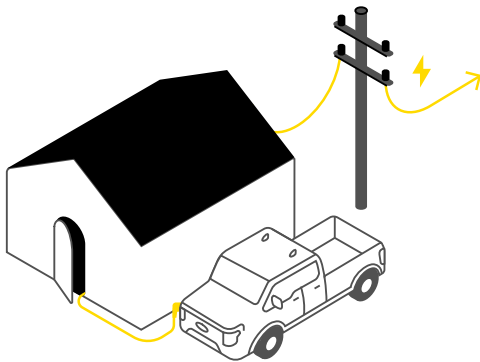

Bidirectional chargers combined with a home energy management system allow electricity to flow from the grid to charge the car's battery, or from the car's battery to your home or grid. Currently very few EVs are capable of V2G, but the number is expected to grow. Bidirectional chargers can save you money on your utility bills when you take advantage of time-of-use rates, and they also replace power generation from some of the dirtiest power plants. During a power outage, bidirectional chargers with a manual transfer switch can be configured to power your home.

Vehicle-to-load (V2L):

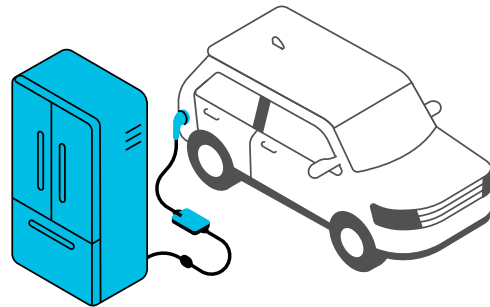

Some EVs allow appliances to be plugged into an outlet on the EV or plug into the charging port via an adapter. The appliances then run independently of the electrical grid, which is convenient during a power outage or when camping. See [Section 10](#) for more details.

Vehicle-to-home (V2H) and V2L:

With a manual transfer switch, your V2L- or V2H-capable EV can replace a stand-alone generator when the power goes out. See [Section 10](#) for more details.

EV CHARGERS

OTHER CONSIDERATIONS

- When charging, consider using your EV or charger's timer to program when to charge to take advantage of low time-of-use electricity prices where available.
- Most chargers are designed to charge in a garage or outdoors. While it is fine to charge a vehicle in the elements, it is better to store the charger in a sheltered location.
- Check that the charging cord length is suitable for your charging configuration. If using an extension cord with a Level 1 charger, make sure it is rated for the charging current the car needs.
- Your battery will have a longer life if you maintain the charge between 20% to 80% and if you minimize high speed charging (level 3 and even high-power level 2).
- If electrical work is required, you will generally require an electrical permit. Be sure to always use CSA-certified electrical equipment and hire a licensed electrician when needed. For safety and durability, ask for commercial-rated 240V outlets, which reduce the risk of poor plug connections.
- Consider installing a lower amp level 2 charger or sticking to a level 1 charger to maximize available capacity on the electrical panel for other electrification upgrades.
- If your electrical panel does not have the capacity to add a 240V level 2 charger, consider adding a circuit-pausing or load-sharing device to share the circuit with another appliance such as your dryer or water heater. See [Section 13](#) for details.

Home Batteries and Backup Generators at a glance

COST

Upfront costs:
\$-\$\$\$\$

IMPLEMENTATION

Easy to difficult

BONUS

No noise or fumes during operation

**EMISSIONS REDUCTION
IMPACT**

Low to medium

10.

Home Batteries and Backup Generators

As climate change is expected to cause more power disruptions, home batteries and backup generators are an increasingly attractive investment. Rural homes in particular are more likely to experience prolonged power outages due to more remote and exposed power lines. Even if outages aren't a concern for you, home batteries can also help shift demand from the grid and take advantage of time-of-use electricity rates.

“

Always have a backup plan to the backup plan.

— Gillian Flynn

Alternatively, if you own an EV or are considering buying an EV, it's a good idea to explore whether it is equipped with V2G or V2L capabilities—they may be able to fulfill all your power needs (see [Section 9](#)).



EV CHARGERS

OPTIONS

Home batteries:

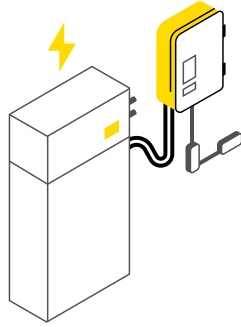

These are larger batteries that can be powered up with off-peak electricity or using excess solar energy, which can then be used during peak times when electricity from the grid can be more expensive. By adding a manual transfer switch, these batteries can power parts of your home during a power outage.

Portable power stations:

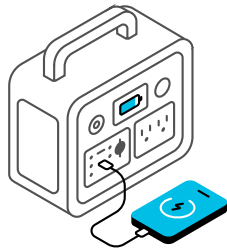

These are basically batteries with a built-in inverter. They can come with a variety of output ports such as conventional 120V outlets, USB ports, DC outlets and more. They are designed to operate one or more pieces of equipment such as a fridge or freezer for hours or longer, depending on the power draw. Some can be charged using solar panels (see below) or even a car's cigarette lighter (slow).

Solar generators:

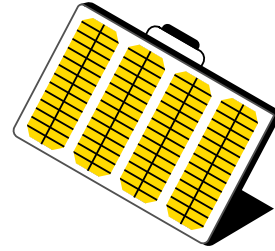

Solar generators are portable power stations that can be charged using portable solar panels. The solar panels are often sold separately.

EVs with V2G capabilities:

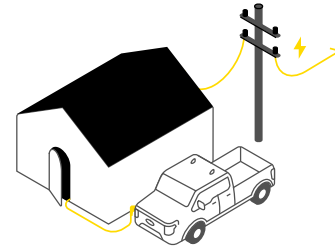

With a bidirectional charger and energy management system these EVs can power your home using the vehicle's battery. A fully charged EV may be able to power the essentials in a home for several days.

EVs with V2L capabilities:

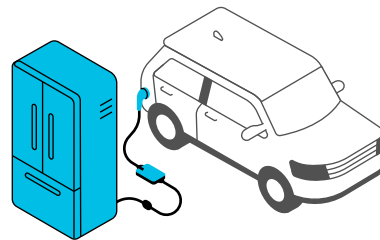

These EVs will either have electrical outlets built in, or you can buy a power strip with an adapter that plugs in to the vehicle's charging port. Using extension cords, you can directly power critical appliances such as fridges, freezers, hot plates, laptops or lights. You can also have an electrician install a manual transfer switch like those used with conventional generators to transfer power supply for the entire home from the grid to your EV battery (V2L capable EVs).

EV CHARGERS

BENEFITS



Battery and solar backup power sources provide resiliency during extreme events and power outages. In some cases, they can even be used to support off-grid living in remote locations.



These electric power sources are quiet, do not generate air pollution, and do not require special storage of flammable fuels.



Unlike fuel generators, battery and solar backup power sources are relatively maintenance free, can be stored inside, and are suitable for use in apartments.



You can save money by charging these systems at off-peak time-of-use rates and using the stored energy to power equipment or even supply electricity to the grid when peak time-of-use rates apply.



Portable power systems can be a great addition to a camping trip or when working at remote sites.

CHALLENGES

- Large home battery systems that can be used to operate a home cost much more than gas generators upfront.
- Batteries have finite lifespans, typically measured in charging/recharging cycles.
- Unlike fuel generators, you cannot buy extra fuel for your batteries when they run out of power because they are recharged with electricity, usually from the grid. Fortunately, power outages are rare in Canada, and most last for only a few hours or less.¹⁴
- Check with your local utility about the maximum inverter size for home batteries and solar installations that can be connected to the grid without paying for a grid impact assessment. The cap is 100 kW in most provinces but in Ontario it is currently 10 kW.
- EVs with V2G capabilities require the installation of a bidirectional charger and a dedicated energy management system.
- Only vehicles designed for V2G and V2L applications should be used to power systems in a home. Using EVs that are not designed for this use can damage the electrical system in the vehicle and void the warranty.

OTHER CONSIDERATIONS

- For electrical work, you will generally require an electrical permit. Be sure to always use CSA certified electrical equipment and hire a licensed electrician when needed. For safety and durability, ask for commercial-rated 240V outlets, which reduce the risk of poor plug connections.
- When shopping for a backup power system, assess your requirements for power output (e.g. the peak power needs of the appliances, measured in watts), and power storage capacity (how long you want the system to run those appliances, measured in watt-hours).
- Some critical equipment such as refrigerators, heat pumps, air conditioners and sump pumps require more power to start up than to run. Make sure your system can handle your equipment start-up needs.
- Have a list of priority appliances that you want to power during an outage. If you are using V2L or a portable power system, make sure you have any necessary extension cords handy and that your system has enough outlets.
- If investing in home batteries, consider an energy management system that can optimize when energy is used to save money in areas with time-of-use rates. During an outage, smart panels can help to extend the power available from batteries by directing power to priority appliances only. See [Section 13](#).
- Consider battery systems designed to be charged with solar panels. This enables you to recharge your battery during longer power outages.

Solar Power at a glance

“

If only there was some kind of an infinite power source that was free to use all day every day...

—
author unknown

COST

Upfront costs:
\$\$-\$\$\$

IMPLEMENTATION

Medium to difficult

ELECTRICAL NEEDS

120V 15-20amp
to 240V 20-30amp

EMISSIONS REDUCTION IMPACT

High

EQUIPMENT LIFESPAN

10-20 years

BONUS

Heat pump water heaters are many times more efficient than alternatives

Links to further resources:

- You can estimate the power generation for solar panels on your roof using [this resource](#)
- [FAQs about rooftop solar panels](#)
- [Comprehensive guide to rooftop solar](#)
- [Guide to clean energy in Canada](#)

11.

Solar Power

Solar photovoltaic (PV) panels generate free electricity from the sun, and the cost to install PV panels has dropped significantly over the past few decades.¹⁵

Adding solar panels to a home can reduce utility bills, reduce emissions, and may even increase a home's resale value. A home that can generate as much electricity as it uses in a year is considered net-zero electricity. If the home

is both net-zero electricity and fully electrified, then it would also be net-zero energy and emissions. Now that is something to brag about! For those who do not own a roof but still want to use solar power, other ways to support renewable energy include buying green energy from your utility or retailer, or investing in or subscribing to a community solar project.

WHAT IS A SOLAR SYSTEM?

A solar system consists of panels that convert sunlight into direct current (DC) electricity and string inverters or microinverters that convert that electricity from DC to alternating current (AC), the form that powers our homes. Some systems also have optimizers to minimize losses.

Most solar systems use solar panels mounted on top of an existing roof surface.

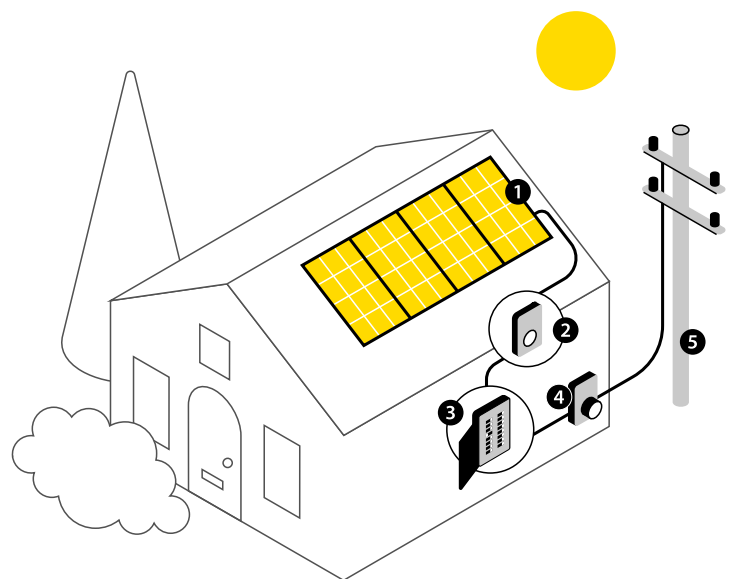

- | | |
|--------------------|-----------------------|
| 1 Solar Panels | 2 Inverter (DC-to-AC) |
| 3 Electrical Panel | 4 Electric Meter |
| 5 Utility Grid | |

“

When there is a huge solar spill it's just called a nice day.

–

author unknown

OPTIONS

Solar shingles:

Solar shingles are an alternative to solar panels that also protect the roof from the elements. They can be used alongside conventional roofing materials on surfaces that are not well oriented for solar.

String inverters:

One string inverter is used to convert the electricity generated from all panels into AC power. This results in simpler installation and lower upfront costs. However, these systems will have shorter warranties (10-13 years) compared to microinverters (25-30 years), and unless power optimizers are used, they may have lower outputs as shading on one panel can reduce the power output of the entire array.

Microinverters:

A microinverter is installed on each solar panel to ensure optimal performance for each panel. While it is easier to add more panels when microinverters are in use, it can be difficult to access and replace a failed microinverter. Microinverters are more expensive upfront than string inverters but come with longer warranties (25-30 years vs 10-13 years).

Power optimizers:

Power optimizers (aka Module Level Power Electronics or MLPE) can be installed on each solar panel when string inverters are used. They help ensure each panel can produce maximum power without being affected by the output of other panels. They have long warranties (20-25 years).

Solar shingles

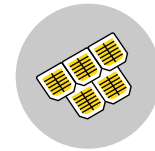

String Inverters

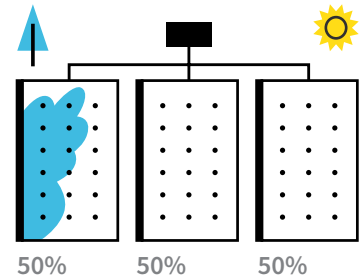

Shade cuts **ALL power** by 50%

Microinverters

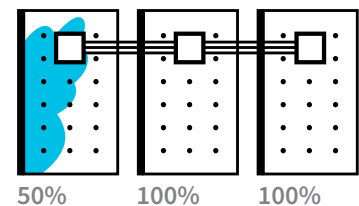

Shade cuts power by 50% on **only one** panel

Power Optimizers

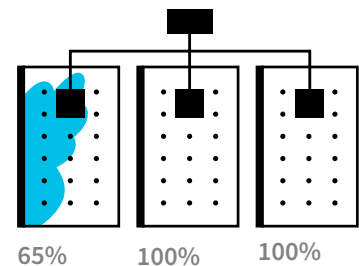

Shade cuts power by 35% on **only one** panel

SOLAR POWER

Green energy retailers:

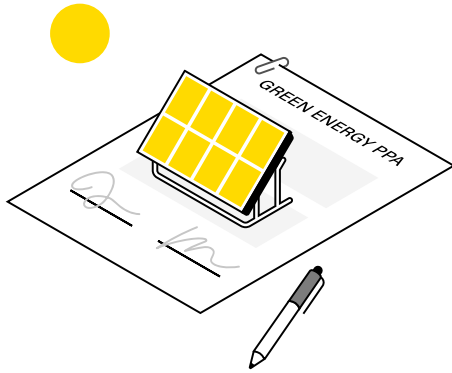

If you are a renter or otherwise not able to add solar panels to your roof, you can buy renewable electricity each month from a green energy retailer. The clean electricity that you pay for is added to the grid mix and you get credit for using that fraction of clean electricity while supporting the growth of renewables.

Community solar, solar farms, solar gardens:

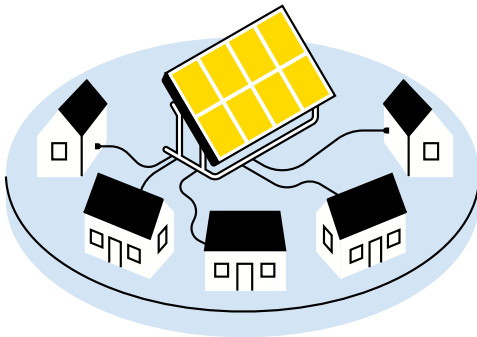

These are large solar installations where community members can purchase some of the solar panels (ownership model) or commit to purchasing a fraction of the electricity generated by the installation (subscription model). Members then receive credits on their electricity bills for their share of the electricity generated by the system. It is a way for residents to invest in solar generation even when they cannot install systems where they live.

Solar hot water:

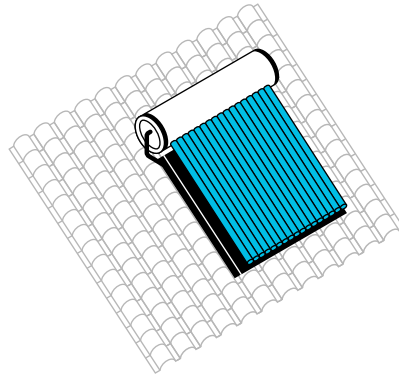

Solar hot water systems are more complex than solar PV and require backup hot water systems for cloudy days. Check out [Section 4](#) for more information on solar hot water.

BENEFITS



With solar panels, you can save on electricity costs. Most provinces and territories use net metering where the electricity generated is either used directly in the home or sent to the grid to earn credits toward your electricity bill.



Solar panels can add up to 3-4% to a home's sale price above those without.¹⁶ You can think of your solar system as an investment in your home's equity.



When solar panels are connected to batteries, they can power your home in the case of a power outage. This allows you to take advantage of both the electricity stored in the battery and the electricity generated by the solar panels. See [Section 10](#) for more information.



Other than regular inspections, solar panels are a low-maintenance addition to your home.

SOLAR POWER

CHALLENGES

- The upfront costs of solar systems are significant and, depending on local utility rates, the payback period can be quite long, especially for smaller systems. Ask about incentives and financing options that will improve the economics for you.
- Solar shingles have higher upfront costs than solar panels.
- Check with your local utility about the maximum inverter size for home batteries and solar installations that can be connected to the grid without paying for a grid impact assessment. The cap applies to the nameplate size of the solar system plus the batteries. The cap is 100 kW in most provinces, but in Ontario it is currently 10 kW.

SIZING ARRAYS

Sizing arrays will depend on your energy use, the space you have available, your electrical panel size, the amount of electricity you want to generate and your budget. To give a better idea of what it would take to go net-zero electricity or net-zero energy, here is what you would need to do:

1. Calculate your average annual electricity use in kWh from past bills.
2. Look for ways to reduce your total electricity use through more efficient equipment or changes to habits.
3. Using the PVWatts calculator, find out how much electricity you can generate with a 1 kW solar array on your home (4 kW is the default).
4. Divide your annual kWh of electricity use by the kWh/yr of generation in your location. This is the size of solar array needed to reach net zero.
5. Check your province's regulations for net metering to learn how the credits are calculated.

ADDITIONAL CONSIDERATIONS

- Expect to generate more electricity in summer and use these credits in winter, but avoid adding a large solar array that generates more electricity than you use in a year because utilities typically do not allow you to carry credits forward for more than a year.
- Solar panels will not provide power to a home during power outages unless they are connected to a battery and wired to safely produce backup power.
- Solar panels can last for decades. Ideally your roof should be made of long-lasting surfaces such as metal, or have been recently resurfaced. Removing solar panels and then reinstalling them to resurface a roof can be a major expense.
- Ideal roofs for solar panels are South, East or West facing, are unshaded, and have few gables, vents and other features.
- Solar panels have expected lifetimes of about 25 years, but in practice will continue to generate electricity for far longer. String inverters may have to be replaced sooner. There is also a market for older solar panels and growing options for recycling end-of-life panels.
- Connection fees and average time to connect solar panels to the grid can vary significantly by region.
- Sometimes permits for solar panels are denied due to grid constraints. Call your local utility to find out if your home is affected. If you are denied a permit, you may try again in a few years as the constraints may have been addressed.
- Electrical panel sizing can also limit the size of solar array that can be installed on your home. Your installer should assess the capacity of your electrical panel.
- Snow guards mounted on the roof can ensure that when the snow melts off the panels, the resulting avalanche is broken up, causing less damage when it hits the ground.

SOLAR POWER

- Squirrels will sometimes build nests under solar panels and chew on the wires. Ask if this is a concern in your area and consider adding squirrel guards.
- You generally do not need to wash solar panels as rain and snow will do the work for you.
- Combining solar panels with batteries and/or an energy management system can maximize how much solar energy is used by your home. This can be important in areas such as Manitoba and Saskatchewan where grid electricity prices are higher than the credits earned for electricity sent to the grid. See [Section 13](#) on energy management for more information.

EXAMPLES OF QUESTIONS TO ASK AN INSTALLER

- How much experience do you have installing residential solar systems?
 - Can you give me references for similar installs and show me the qualifications of the installers who will do the work? Do you have worker's compensation insurance?
 - Do you check that my roof is structurally fit to support solar panels? Do you check if my electrical panel can support the proposed solar panels?
 - What size system do you recommend? How much electricity do you expect it to generate per year?
 - What is the total cost of the system, and the upfront deposit? What financing options do you offer?
 - Will I be required to make any roofing or panel upgrades? If so, what would be the estimated cost?
 - Will you be taking care of all permits?
 - Are you aware of any incentives that I qualify for? Do you secure building permits for the installation?
 - What will my net savings be? What utility rate assumptions are included in your calculations?
 - If your province or territory has options for electricity rate structures, which rate structure provides the best savings?
 - How long will the whole process take?
 - Who deals with the utility and arranges for connections and inspections?
 - How do you protect my roof surface during installation and ensure water cannot enter through the mountings?
 - Where will you run the wires from the solar array to the electrical panel and how will you make these visually unobtrusive?
 - What is the estimated cost to remove and reinstall the solar panels when my roof surface needs replacing?
 - Can I add more panels later?
 - Is the system configured so I can add a battery system later?
 - What do the warranties cover and what are their durations? If the company fails, who should I contact about warranties and replacements?
 - How can I monitor the performance of the system?
- NOTE:** It is always a good idea to get multiple quotes before selecting an installer.

CASE STUDY

Home electrification:

Amelie and Darren of Airdrie, Alberta dreamed of getting their home off the gas network.

It took professional air sealing, a ground-source heat pump pre-heater tank with an electric water tank, and a ground source heat pump (GSHP) with a vertical loop installed in their backyard.

As a bonus, they installed solar panels that should offset their annual electricity use.

The project achieved a 79% energy savings and was paid for with a renovation loan added to their mortgage, a Greener Homes Grant (GSHP) and a personal bank loan for the solar.

More details can be found at [Green Communities Canada](#).



12.

Avoiding an Electrical Panel Upgrade

As we have seen, everything in and around your home can be electrified. But electrifying your home can involve more than just replacing fueled appliances with electric ones. Sometimes a home will require upgrades to wiring, to the electrical panel, and even to the electrical service. With planning, there are ways to limit the amount of work done and the associated costs.

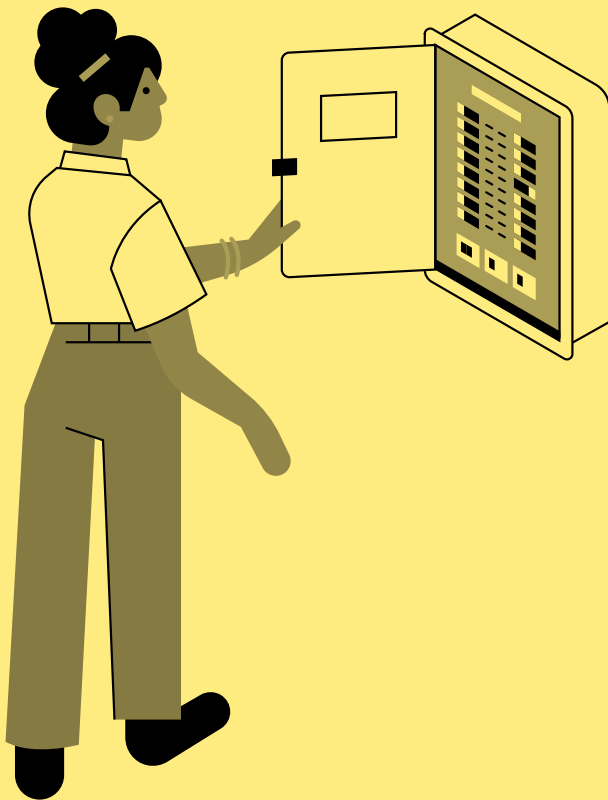

Links to further resources:

- [Rewiring America, Wire your home for electrification](#)
- [Redwood Energy, Watt diet Calculator](#)
- [B2E, Home Electrification: Service Upgrade Not Required!](#)

HOW TO AVOID AN ELECTRICAL PANEL UPGRADE

- Most homes with electrical panels of 100 amps or more won't need a panel upgrade to electrify home heating or appliances. But an upgrade may still be your best option if you plan to add more electric appliances in the future, or if your panel is constrained. Be sure to explore all your options and get quotes from your electrician before deciding.
- **Appliances that provide two functions** in one such as a combined range and stove or a combined washer-dryer will use less electrical panel space than separate appliances.
- **Consider more efficient appliances or appliances that draw less power.** For example, electric water heaters that use a 15-amp circuit rather than 20 or 30 amps are available. Similarly, a 120V condensing dryer will require a 15- or 20-amp circuit while conventional dryers require a 30-amp circuit.
- **Consider lower capacity EV chargers.** An overnight charge with a lower capacity EV charger may provide all the range you need for most of your everyday needs, freeing up electrical panel capacity. Use commercial fast chargers for those occasional situations when additional range is necessary to avoid the cost of upgrading your electrical panel or service.
- Some jurisdictions allow the total circuits on an electrical panel to exceed the panel's rated capacity if **historical load calculations** show that peak loads from those circuits will not exceed safe limits for the system (Canadian Electrical Code Rule 8-106). Talk to your electrician to find out if this is an option for you.
- **Ask your installer if a backup heater** is required with a heat pump in your area. A backup heater takes up a lot of space on an electrical panel and may not be required if the heat pump is sized and designed for your climate, or if a ground source heat pump is used. Cold climate air source heat pumps may also be able

to meet heating load requirements to temperatures as low as -30°C (-22° F) and are getting better every year (see [Section 2](#)). If a supplemental heater is required, be sure that it is not oversized for your needs.

- **Insulating and air sealing a home** can reduce the size of heat pump you need, lowering the load on the electrical panel. These investments will save money for heating and cooling and make a home more comfortable too.

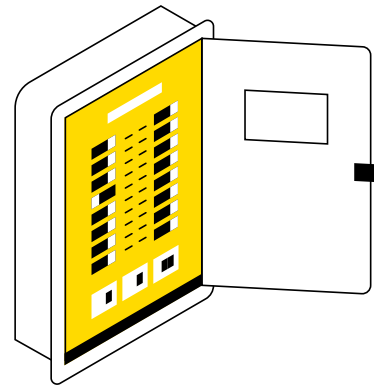

- **Consider energy management systems**, including load share devices, circuit pausers, and smart panels. These maximize the available capacity on an electrical panel by controlling and prioritizing electrical demand from multiple appliances. See [Section 13](#) for more information.
- If you are out of room for more breaker switches but still have capacity on your panel (ie your breakers add up to less than your panel's capacity), ask your electrician about using skinny breakers or subpanels. **Skinny breakers** (aka tandem or twin breakers) allow two circuits to use the space of one and optimize slot management and can help with panel space limitations. **A subpanel** is typically used to separately distribute and control power to an area of a home (e.g. workshop or secondary suite). Note that skinny breakers and subpanels do not change the rated capacity of the panel.

AVOIDING AN ELECTRICAL PANEL UPGRADE

OTHER CONSIDERATIONS

- Plan ahead and get your electrician to add circuits for all your future electrification plans. Consolidating all the work into one project can save you money and time.
- An electrical panel upgrade can cost a few thousand dollars, but if an electrical service upgrade is needed, it can add many more thousands of dollars to the cost. Contact your local utility to ask about the cost of electrical service upgrades, as these can vary significantly depending on your region.
- Upgrading your electrical service can take time so it is essential to plan ahead.
- Upgrading an electrical panel enables future electrification projects.
- When homes find efficient ways to avoid having to upgrade electrical panels and electrical service, they also help to avoid upgrades to the electrical distribution system which we all pay for through our electricity bills (and taxes).

An electrical panel (aka breaker box, fuse panel, load center, distribution box) takes electricity from the grid and distributes it to circuits in different parts of your home. Each circuit has its own breaker and typically serves all electrical needs for one area of the house, or for a single high-power appliance such as a range, dryer or heat pump. If appliances try to draw too much power, the circuit breaker will trip to protect you and your home from electrocution or electrical fires. Each circuit and associated breaker will have a voltage and amp rating. If your home still uses fuses instead of circuit breakers, it is time for an upgrade.

The electrical panel is a grey, beige or white box, often located in a basement or garage. The size of panel can be determined by looking for the number written on the

main breaker switch, which is typically separated from the other breakers on the panel. The most common size is 100 amps or 200 amps. An electrician can help you to assess whether you can avoid an electrical panel upgrade using historical load calculations or load sharing devices.

The electrical service is determined by the size of the local transformer and the wiring that goes to your home. The electrical panel and electrical service ratings may not be the same. Your electrical utility can tell you what service is provided to your home and what costs would be involved in upgrading the service. If the wires are overhead, the upgrade may be low or no cost. However, if the wires are buried or if a transformer upgrade is needed, the cost can be many thousands of dollars.

240V SOCKETS TYPES

20A



NEMA 6-20

30A



NEMA 6-30



NEMA 10-30



NEMA 14-30

50A



NEMA 6-50



NEMA 10-50



NEMA 14-50

60A



NEMA 14-60

CASE STUDY

Avoiding a panel upgrade:

After buying a new EV, Colin wanted to install a level 2 home charger. The problem: his electrical panel did not have the capacity to add his 48-amp level 2 charger.

But Colin suspected that the household's peak energy use was far less than the sum of the breakers on his panel. So, he reached out to his local utility to prove it. Sure enough, historical data showed that the highest historical demand for electricity was far less than the maximum rated capacity of his 100-amp panel.

With this data in hand, he was able to work with an electrician to have his EV charger installed without a panel upgrade. He has since learned that his EV is limited to 32 amp charging and that he could have installed a lower capacity charger (definitely something to check!). But he is still happy with his EV.



“

[My EV] is quieter, more comfortable, faster, and in every way a better experience than an internal combustion vehicle

—
Colin

Energy Management Systems at a glance

Load share devices, circuit pausers and smart panels:

COST

Upfront costs:
\$\$-\$\$\$

IMPLEMENTATION

Difficult

BONUS

These can help you to avoid an electrical service and panel upgrade.

Smart thermostats and appliances:

COST

Upfront costs:
\$-\$\$

IMPLEMENTATION

Easy

BONUS

Opportunities to save money with time-of-use rates efficient than alternatives

EMISSIONS REDUCTION IMPACT

Low to medium

For more information

- [Rewiring America Circuit Breakers: debunking electrification myths](#)
- [B2E Home Electrification: Service Upgrade Not Required!](#)

13.

Energy Management Systems

“

**...the more we share,
the more we have**

—
Leonard Nimoy

With electrification, the more we share, the more electrical capacity we have. Energy management systems play an essential role in facilitating this sharing. These systems are designed to provide more flexibility in directing energy to circuits.

WHAT IS A ENERGY MANAGEMENT SYSTEMS

Rather than treating all electrical uses equally in a home, an energy management system allows you to prioritize some uses over others, allowing electrical panel capacity to be shared—and letting you use a smaller electrical panel to accommodate more loads. Energy management systems are evolving rapidly as competitors develop new features and applications.

The most basic energy management systems consist of load share devices and circuit pausers that allow two circuits to share space on the electrical panel. Today, one of these circuits will typically connect to an EV charger. If more than two circuits are to be shared or if you want better control of the electrical loads in a home, smart panels should be considered.

Smart thermostats and appliances are another way to manage energy use more directly through the appliance itself.

ENERGY MANAGEMENT SYSTEMS

OPTIONS

Load share device

Two appliances can share one circuit on the electrical panel but only one appliance can work at any given time

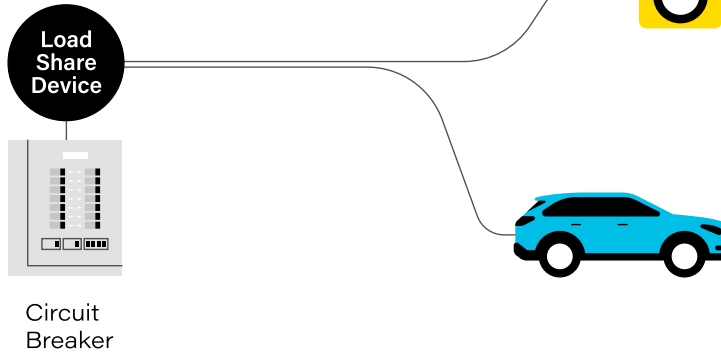

PRIMARY (Power on Demand)

- Electric oven, cooktop
- Electric dryer
- Electric heaters
- A/C (climate dependent)
- Electric water heater

SECONDARY (Powered when primary not in use)

- Type 2 EV charger
- Shop equipment
- A/C (climate dependent)
- Electric water heater

Load share device with primary and secondary loads allow two appliances to share one circuit and one breaker on the electrical panel. Only one of the appliances can be in use at one time. The primary load has the power by default and the secondary load can only draw power when the primary load is off. For example, a stove may be

the primary load and an EV charger can be a secondary load that is only used at night after cooking is done. Some load share devices will provide a small current to both appliances to ensure internal clocks and displays continue to operate.

Circuit pausers:

The connected appliance will be paused only when the total output of the electrical panel is above a threshold

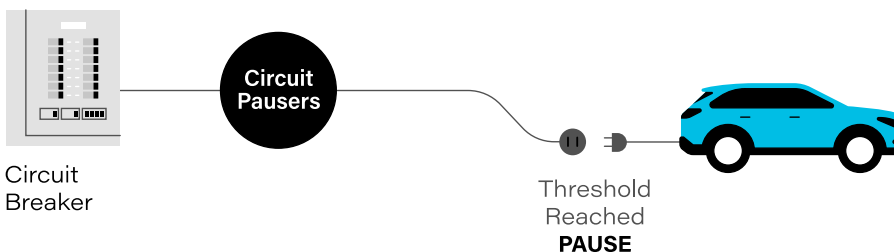

IDEAL FOR

- Electric water heater
- Electric dryer
- Type 2 EV charger
- Shop equipment
- A/C (climate dependent)

With circuit pausers, the connected appliances will only draw power when the demand from all devices in your home is below a threshold. If the threshold is reached, power to the connected appliance is paused

until demand falls back below the threshold for a set amount of time (often 15 minutes). EV chargers are ideal for circuit pausers because interruptions to their power draw are unlikely to have noticeable effects.

ENERGY MANAGEMENT SYSTEMS

Smart electrical panels:

Balances loads to accommodate more electric appliances and optimizes energy use

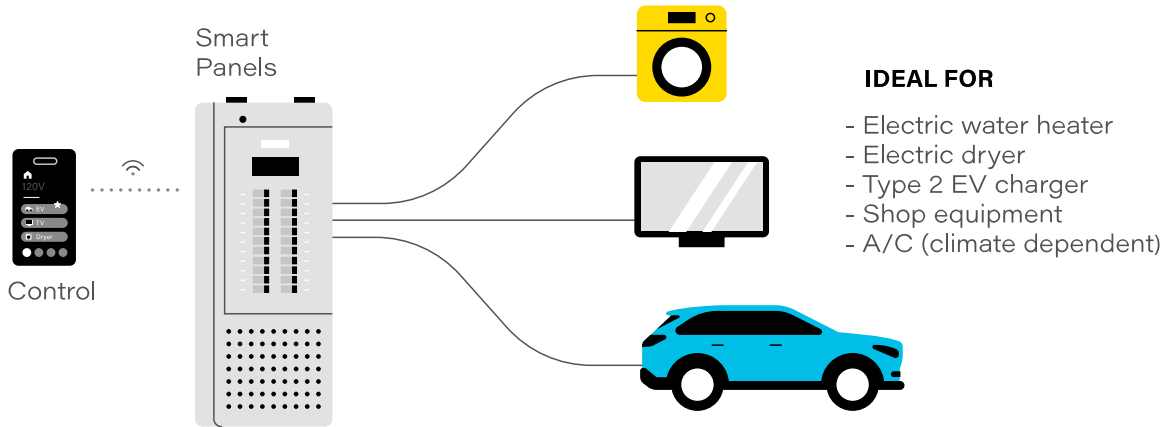

- IDEAL FOR**
- Electric water heater
 - Electric dryer
 - Type 2 EV charger
 - Shop equipment
 - A/C (climate dependent)

Smart electrical panels monitor power use in real time and use software to allow for load management across multiple circuits. They generally replace the existing panel. Where permitted, homeowners can program the panel to fit more electrical loads on the panel by prioritizing some appliances over others. Smart panels also help optimize when energy is used to save money in

areas with time of use rates or to use electricity generated by solar panels. Some systems will use machine learning to recommend changes that reduce energy use or maximize bill savings. During an outage, smart panels can help extend the power available from batteries by prioritizing only essential loads.

ENERGY MANAGEMENT SYSTEM FEATURES:

Equipment	Cost	Number of circuits managed
No change	NA	
Panel upgrade	\$\$\$	None
Load share	\$\$-\$\$\$	Two
Circuit pauser	\$\$-\$\$\$	One
Smart panel	\$\$\$	Multiple

Smart thermostats:

Allow for monitoring and control of your heating and cooling systems through internet-connected devices. Since heat pumps are more efficient when home temperatures are maintained at a relatively steady temperature, there are fewer opportunities to save energy with a programmable or smart thermostat. Where smart thermostats may be valuable is in minimizing the use of backup (auxiliary) heaters, allowing for remote temperature control (while on vacation for example), and providing maintenance reminders. Be sure that your smart thermostat is compatible with your heat pump and with the backup heater.

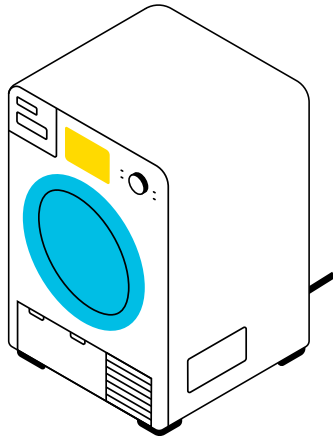
Smart appliances

Also available and can remotely set oven temperatures and monitor cooking progress, schedule laundry cycles for convenience or to avoid times when electricity generation relies heavily on fossil fuels, or set your water heater to only run during low time-of-use rates. They add convenience and will sometimes reduce overall energy use but expect to pay more for smart appliances.

OTHER CONSIDERATIONS

- Before investing in energy management systems, consider ways to avoid electrical panel upgrades, including using appliances with lower power draws and having an electrician calculate panel capacity using historical load calculations. See [Section 12](#) for more information.
- Upgrading to a smart electrical panel enables future electrification projects and can help avoid upgrades to the electrical distribution system.
- Some smart panels have an automatic transfer switch integrated which will automatically shift your home from drawing power from the grid to drawing power from a battery during a power outage.
- Energy management systems are evolving rapidly. Be sure to seek out electricians who are familiar with current models and regulations.
- Some energy management systems require additional software or hardware with separate costs. Be sure to always ask about the full upfront and operational costs of the system.

CASE STUDY

Net-zero-emissions home:

Heather and Eric started investing in low-carbon upgrades to their 1992 semi-detached Southern Ontario home out of a desire to do what they could to build a more climate-safe future for their children.

It started in 2010 when they replaced a leaking gas water heater with a more efficient electric water heater set on a timer to take advantage of lower overnight electricity rates in Ontario.

After some insulation upgrades to the attic and foundation floor, they installed a cold climate air source heat pump in 2021 and disconnected from the gas line.

The last part of the journey was the installation of 8.16 KW of solar panels that generate enough electricity in a year to offset their household's annual electricity use.



“

I have been so much more comfortable in our home since installing the heat pump, I would never go back to a gas furnace!

–
Heather

14.

Options for Renters

Renters and condo/strata owners generally do not have input on the types of equipment that are installed in a home, but that does not mean that they have no power to electrify their homes. There are many portable electric options for such households, and when a

renter moves, they can take that equipment with them. Often these options come with co-benefits. Renters and condo/strata owners can also advocate for investments in building envelopes, in electric equipment, and in EV chargers.

Additional resources

- [Make your condo EV-ready guide](#)
- [EV-ready bylaw tracker for multiunit residential buildings](#)
- [Guide to EV charging in MURBs](#)
- [How to talk to a landlord about electrification](#)

SPACE HEATING OPTIONS

Window heat pumps:

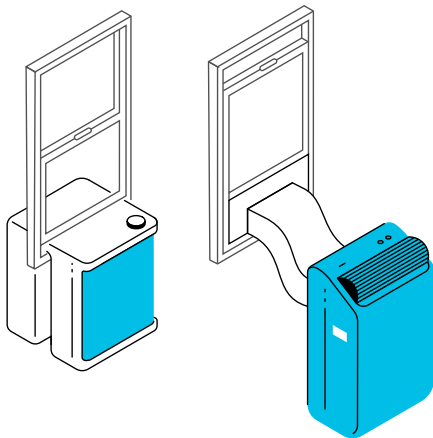

Small air source heat pump units with hoses that fit into a **window opening are now available** (see [Section 2](#)), and versions that hang like a **saddle across a window ledge** are coming soon. These plug into a regular wall outlet and can be effective at heating a room in winter and providing cooling in summer, but they will still require another heating system for the coldest days. Keep in mind that these units will dehumidify your home as well, and units with drain pumps can help to avoid the need to empty condensate pans multiple times a day when in full use.

Some of the most compact room thermal storage units can be plugged into a regular outlet, as long as that the circuit is not used for other purposes (see [Section 3](#)). These are best suited to regions with time-of-use rates, where they can be charged when electricity rates are low.

COOKING OPTIONS

Single element induction cookers:

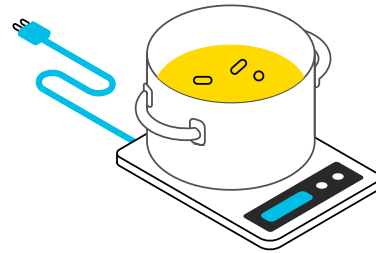

Cost-effective options that plug into regular kitchen outlets (see [Section 5](#)). They offer fast, controlled heating with no combustion gases and easy cleanup. When combined with a countertop toaster oven, many renters may realise that they never use their gas stove.

Electric barbecues:

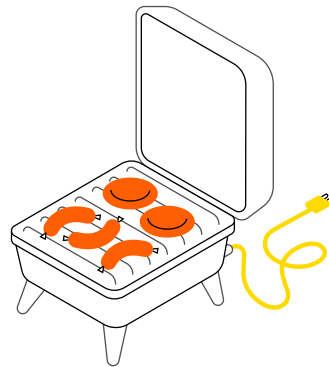

Another great option (see [Section 8](#)). In many cases, these can be used in places where conventional barbecues are not allowed, such as balconies. Check first that there is a convenient outlet to plug it into and that your building allows electric barbecues.

OPTIONS FOR RENTERS

RENEWABLE ELECTRICITY

Solar panels:

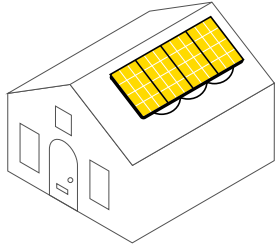

Renters and condo owners may not be able to install **solar panels** where they live, but there are still ways to use solar power or invest in solar projects (see [Section 11](#)).

Green energy retailers:

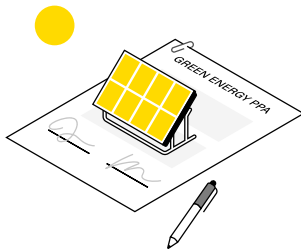

Sell renewable electricity to renters and homeowners alike. The clean electricity you pay for is added to the grid mix and you get credit for using that fraction of clean electricity while supporting the growth of renewables.

Community solar, solar farms, and solar gardens:

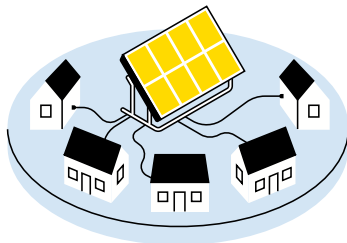

Large solar installations where community members can purchase some of the solar panels (ownership model) or purchase a fraction of the electricity generated by the installation (subscription model). Members then receive credits on their electricity bills for their share of the electricity generated by the system.

OTHER ELECTRIFICATION OR ENERGY SAVING OPTIONS

Many renters and condo/strata owners still maintain yards and driveways. Go to [Section 8](#) for electric options for all tools for yards and driveways.

Ventless dryers:

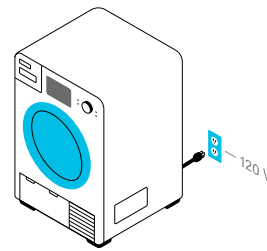

Ventless dryers especially those that are 120V, can be added to a home and save the cost, hassles, and concerns about lingering dirt or perfumes when using shared dryers and laundromats (see [Section 6](#)).

Rack or clothesline

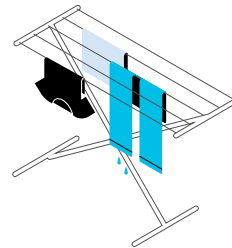

Drying clothes on a **rack** or **clothesline** is another way to avoid the cost and emissions from conventional gas dryers. And that fresh outdoor scent on sheets is hard to beat!

OPTIONS FOR RENTERS

Even if you cannot electrify the space and water heating equipment in your home, you can still reduce the carbon emissions from these heating systems and save money through simple measures.

Tips for reducing gas space heating include:

- » Turn down the thermostat at night or when away during the day (this is different from a heat pump where it is more efficient to keep a steady temperature);
- » Ask the landlord to install a programmable or smart thermostat if one isn't already installed;
- » Consider using sweaters, socks, slippers and blankets to stay warm.
- » Clean or replace the furnace filter regularly;
- » Apply heat shrink plastic on windows in winter and add weather stripping where possible; and
- » Maximize natural warmth by opening the curtains during the day to let the sun in and closing them at night to minimize heat loss.

Tips for reducing hot water use include:

- » Install low-flow showerheads and faucets
- » Choose efficient appliances such as washing machines and dishwashers
- » Wash clothes in cold water
- » Wait until you have a full load of laundry before using the washing machine
- » Fix water leaks
- » Insulate hot water pipes
- » Set your water heater tank's thermostat at 60°C (140°F) and use a mixing valve

EV CHARGING

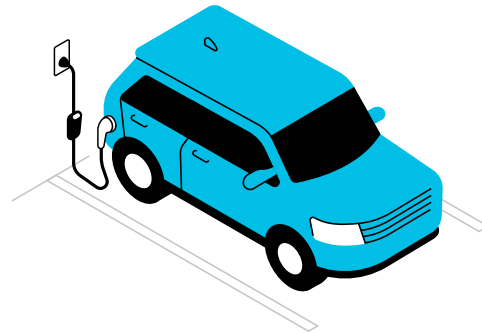

Most EVs and other electric mobility devices can be charged using a regular outlet. EVs will take longer to recharge this way than with a level 2 charger, but with more than 60 km of range from an overnight charge, this may be all that you need (see [Section 9](#)).

ADVOCATING FOR ACCESS TO ELECTRIFIED AND LOW-CARBON EQUIPMENT

In some provinces, condo or strata boards must install EV charging equipment upon request unless exemptions apply. Incentives are also available in some provinces and territories for installing EV chargers at multi-residential buildings. The first step is usually to have a discussion with the condo/strata board or property manager with the goal of submitting a formal application to the board for EV charging.

Renters and condo/strata owners can also engage with property managers or owners to highlight the benefits of building envelope upgrades and equipment electrification as well as incentives available to help finance the investments. These benefits can include lower energy use, improved indoor air quality, resilience to extreme heat events, insulation from rising carbon prices, lower insurance premiums, and reduced tenant turnover.¹⁷

15.

Electrification Incentives

“

**Governments
use incentives to
help individuals
and groups make
decisions that
advance the greater
good**

–

author unknown

Loans, grants and other subsidies for electrification help to reduce emissions, curb air pollution, and improve housing affordability. Incentives can come and go rapidly and may be available from all levels of government, so be sure to always ask if incentives are available.

It is always a good idea to check for incentives when investing in home upgrades.

List of incentives

Below is a list of incentives available for the home electrification equipment covered in this toolkit at the time of writing. The list is not intended to be exhaustive, and some programs may have expired. Using the program's name in a search will provide more details for active programs.^{18, 19}

FEDERAL

- [Greener Homes Loans](#): Up to \$40,000 in zero-interest 10-year loans are available for home retrofits, heat pumps and solar panels.
- [Oil-to-Heat-Pump Affordability Program](#): Provides grants of up to \$10,000-\$15,000 to lower-income households switching from oil heating to heat pumps.

PROVINCIAL

BC

- [CleanBC Better Homes and Home Renovation Rebate Program](#): Supports heat pumps, water heaters and building envelope upgrades.
- [Clean BC Better Homes site for provincial and municipal rebates](#): Rebate and incentive programs available for electric heat pumps, electric water heaters, building envelope upgrades, dryers and EV chargers, with some rebates targeting Indigenous communities.

MB

- [Efficiency Manitoba My Home Rebates](#): Rebates and incentives available for heat pumps, building envelope upgrades, and solar systems with some dedicated Indigenous programs.

- [Manitoba Hydro Home Energy Efficiency Loan](#): For heat pumps, electrical equipment upgrades, water heaters, EV chargers, and building envelope upgrades.
- [Green Energy Equipment Tax Credit](#): For GSHPs and solar thermal systems.

NB

- [SaveEnergy NB Home Programs](#): Incentives for energy efficiency upgrades, building envelope upgrades, and heat pumps.

NL

- [TakeCHARGE rebates and programs](#): Loans and incentives for building envelope upgrades and oil to electric conversions.

NS

- [Efficiency Nova Scotia Residential Incentives](#): Rebates and incentives for heat pumps, efficient appliances, solar systems, and building envelope upgrades.

NT

- [Arctic Energy Alliance Residential Incentives](#): Rebates for building envelope upgrades, dryers, renewable energy, and EV chargers.

ELECTRIFICATION INCENTIVES

NU

- [Renewable Energy Cabin Grant Program](#): Incentives for renewable energy systems for cabins in remote locations.

ON

- [Enbridge Home Efficiency Rebate](#): Incentives for Enbridge customers for heat pumps and building envelope upgrades.
- [SAVE ON ENERGY For Your Home Programs](#): Incentives for energy efficiency products and free heat pumps for income-eligible households with electric heating.

PE

- [Prince Edward Island Energy Efficiency Rebates and Programs](#): Rebates and incentives for heat pumps, building envelope upgrades, energy efficient equipment, and solar systems. Some incentives target rental housing and low-income households.

QC

- [Quebec Residential Energy Efficiency Programs](#): Incentives for heat pumps, thermal storage, and building envelope upgrades.
- [LogisVert Efficient Homes Program](#): Incentives for heat pumps, induction ranges, heat pump dryers, and insulation, plus air sealing and solar heating systems.

YT

- [Good Energy Rebates](#): Rebates for building envelope upgrades, heat pumps, solar hot water systems, energy efficient appliances, and EV chargers.

MUNICIPALITIES

- Many municipalities now offer low interest financing for residents looking to make low carbon investments in their homes.

16.

Amplifying the Impact Through Conversations

“

The most important thing you can do to fight climate change is talk about it

–

Katharine Hayhoe

Electrifying our homes is a practical way to reduce emissions and improve our quality of life. It can make our homes safer, healthier, more comfortable, and more energy efficient. It's also one of the most effective ways to reduce our greenhouse gas emissions and support a better future for us and for future generations.

Sharing your electrification journey is a free and effective way to transform that individual impact into a collective one. Talking about why climate change matters to you can help others see it as a concern worth acting on, and seeing one person make meaningful progress can foster hope and encourage change. Messages about electrifying our homes (and about cost savings and climate change) have the most

impact when they are shared by people we know and trust—so be that trusted source for the people in your life.

Talk to your friends, family, colleagues and neighbors about your own electrification journey including your successes, and challenges—and how you solved them. Share how these investments support the values and concerns you have in common. Help others to see their electrification opportunities and celebrate when they reach milestones on their journey.

Do what you can, talk about it, and support others on the journey. And when you can, do some more. Together, we can do this!

17.

Ways Community Groups Can Help

BULK PURCHASE AGREEMENTS

One way to reduce the cost of electric appliances is to organize a community bulk purchase. For more complex equipment like heat pumps, groups can put out a request for proposal for installers to bid for the installation of multiple units in many homes. When enough people sign up, discounts of up to 20% can be achieved.²⁰ This also sends a signal to retailers and installers that these products are in demand, helping to build technology awareness, installer capacity and greater product availability.

The Harbord Village Residents Association negotiated a bulk buy discount for induction stoves at Best Buy. For more information, see harbordvillage.com/projects/netzero-carbon-project/induction-stove-bulk-buy

COMMUNITY SOLAR

Community solar projects, also known as solar farms and solar gardens, are large solar installations where community members can purchase some of the solar panels (ownership model) or purchase a fraction of the electricity generated by the installation (subscription model). Members then receive credits on their electricity bills for their share of the electricity generated by the system.

The first step in developing community solar is to find a group of like-minded people interested in investing in the project. There are a lot of decisions to be made and stakeholders to engage. The project can be expected to take several years to complete, but the results may well justify the effort—most notably access to clean electricity and meaningful relationships with others in the community.

There are many guides available to help groups establish community solar projects. For example, the Pembina Institute has developed an Alberta community solar guide that includes a general project development process: www.pembina.org/reports/alberta-community-solar-guide.pdf

HOME TOURS AND CASE STUDIES

Home tours and case studies introduce a human touch on electrification activities. They can be an opportunity to get unbiased information and advice from people who have firsthand experience of the electrification options. Home tours and case studies are ideally organized and published by community groups that have strong links to the community and effective communications channels.

- rpssc.energy.gov/proven-practices/proven-practices-host-home-events-jump-start-outreach
- climatefriendlyhomestour.ca/

WAYS COMMUNITY GROUPS CAN HELP

EQUIPMENT LOANER PROGRAMS

Portable induction cookers are ideal for lending out for loaner programs, allowing individuals to test them out before making a purchase. The kit should include a fact sheet and a magnet to help borrowers identify which of their pots will be compatible. Many borrowers will be impressed with the improved cooking experience as well as the ease of cleaning and better indoor air quality when using induction cookers. In California, an induction cooktop lending program reported that 72% of borrowers expressed interest in switching to induction cooking.²¹

Several libraries offer thermal cameras on loan to help residents identify places with air leaks and inadequate insulation (see examples are [Ottawa](#) and [Nelson](#)).

WORKSHOPS AND EVENTS

Many public groups have organized events and workshops that promote home electrification. Some examples include:

- » “Electrify Everything” workshops where homeowners and experts share their knowledge and experience;
- » “Women EV Nights” where women support other women in learning about EVs;
- » “[Heat Pump Parties](#)” where homeowners invite community members to admire and celebrate the electrification of space heating;
- » “Introduction to Induction” events where homeowners share their experiences with the technology and chefs demonstrate their use.

ELECTRIFICATION SUPPORT GROUPS

The [Pocket Change Project](#) is a community group in Toronto that supports each other in reducing their individual and collective carbon footprints. A retrofit coach is available in the community to help homeowners to plan their electrification roadmap. The group holds regular events to share information, have conversations, and celebrate successes. It is a great demonstration of the power of people and their communities.

Other communities have taken a simpler approach by setting up Facebook groups to share information and support each other in installing heat pumps or other electric appliances.²²

GAMIFYING ELECTRIFICATION

[Canadian Geographic’s “Live Net Zero” challenge](#) selects households from across the country every year to participate in a carbon reduction competition. There are six challenges to the competition, including home improvements, building envelopes, heating and cooling systems, and energy efficiency. That is a great way to add some excitement to electrification.

Electric and smart home appliances are another opportunity to gamify energy savings and emissions reductions. Smart appliances can be programmed to operate during times when energy prices are low or when electricity is generated primarily from renewables. Is your community ready to challenge each other to reduce energy and emissions with smart appliances?

What Can Your Community Do?

Appendices

Appendix 1: Equipment operating cost by province and territory (updated April 2025)

THE OPERATIONAL COSTS FOR ELECTRIFIED COMPARED TO NON-ELECTRIFIED EQUIPMENT BY PROVINCE

Equipment	AB	BC	MB	NB	NL	NT	NS	ON	PE	QC	SK	YT	CA
Space heating													
ASHP	>>	>	>>	<	<<	>	<	>	<	<	>>	<<	>
ccASHP	>>	=	>>	<	<<	>	<	>	<<	<<	>>	<<	>
Hybrid ASHP	>>	=	>	<	<<	<	<	>	<<	<<	>>	<<	>
GSHP	>	<	>	<<	<<	<	<<	<	<<	<<	>	<<	<
Air to water HP	>>	<	>>	<	<<	>	<	>	<<	<<	>>	<<	>
Portable ASHP	ND	ND	ND	ND	ND	ND	ND	ND	ND	ND	ND	ND	ND
Water heater													
Electric tank	>>	>>	>>	>	=	>>	>	>>	>	>	>>	<	>>
Electric tankless	>>	>>	>>	>	=	>>	>>	>>	>	>	>>	<	>>
Heat pump water heater	>	<	>	<<	<<	<	<<	<	<<	<<	>	<<	<
Heat pump water heater (120 V)	>>	>	>>	<	<<	=	<	>	<	<	>>	<<	>
Solar water heater	>>	<	>	<	<<	<	<	=	<<	<<	>	<<	=
GSHP desuperheater	>	<	>	<<	<<	<	<<	<	<<	<<	>	<<	<
Cooking ranges													
electric coil range	>>	>	>>	<	<<	>	=	>	<	<	>>	<<	>
radiant range	>>	>	>>	<	<<	>	=	>	<	<	>>	<<	>
induction range	>>	=	>	<	<<	=	<	>	<	<<	>>	<<	>
portable induction cooker	>>	=	>	<	<<	=	<	>	<	<<	>>	<<	>
oven	>>	>	>>	<	<<	>	=	>	<	<	>>	<<	>
Dryers													
electric resistance	>>	>>	>>	>	=	>>	>	>>	>	>	>>	<	>>
condensing	>>	>>	>>	>	=	>>	>	>>	>	>	>>	<	>>
heat pump	>>	>	>>	>	<	>	>	>>	<	<	>>	<<	>>
120V	>>	>>	>>	>	=	>>	>	>>	>	>	>>	<	>>
combined washer and dryer	>>	>>	>>	>	=	>>	>	>>	>	>	>>	<	>>

APPENDIX

Equipment	AB	BC	MB	NB	NL	NT	NS	ON	PE	QC	SK	YT	CA
Fireplaces													
electric fireplace	>>	>	>>	=	<	>	=	>	<	<	>>	<<	>
water vapour electric fireplace	>>	>	>>	=	<	>	=	>	<	<	>>	<<	>
Barbeques													
electric	>>	>>	>>	>	>	>>	>>	>>	>	>	>>	<	>>
Other equipment													
electric pool heater	>>	>>	>>	>	<	>>	>	>>	>	>	>>	<	>>
heat pump pool heater	>	<	=	<<	<<	<<	<<	<	<<	<<	>	<<	<
Solar pool heater	ND	ND	ND	ND	ND	ND	ND	ND	ND	ND	ND	ND	ND
EV chargers													
level 1	<<	<<	<<	<<	<<	<	<<	<<	<<	<<	<<	<<	<<
level 2	<<	<<	<<	<<	<<	<	<<	<<	<<	<<	<<	<<	<<
bidirectional	<<	<<	<<	<<	<<	<	<<	<<	<<	<<	<<	<<	<<

Notes:

- **NU** is not included because fuel prices are not available.
- **>>** the operating cost is two or more times the operating cost of comparable gas equipment.
- **>** the operating cost is more than 10% over that of comparable gas equipment but less than double the cost.
- **=** the operating cost is within 10% of the operating cost of comparable gas equipment.
- **<** the operating cost is less 90% of the operating cost of comparable gas equipment but less than half the cost.
- **<<** the operating cost is half or less of the operating cost of comparable gas equipment.
- **ND** insufficient data available.

Appendix 2: Equipment operational GHG emissions by province and territory

Even electrified equipment can still be responsible GHGs if the electricity that powers the equipment generates GHG emissions. How much GHGs are generated varies greatly by province and territory depending on how much generation comes from fossil fuel power plants.

Although operating electric equipment in some provinces and territories results in higher overall GHG emissions today, this will not be true for long. The federal government is working with the provinces and territories to move towards greater generation from renewable sources such as hydropower, wind, and solar.

THE EMISSIONS FOR ELECTRIFIED COMPARED TO NON-ELECTRIFIED EQUIPMENT BY PROVINCE AND TERRITORY

Equipment	AB	BC	MB	NB	NL	NT	NS	NU	ON	PE	QC	SK	YT	CA
Space heating														
ASHP	>	<<	<<	<	<<	<	>	>>	<<	<	<<	>>	<<	<<
ccASHP	=	<<	<<	<	<<	<	>	>>	<<	<	<<	>	<<	<<
Hybrid ASHP	=	<<	<<	<	<<	<<	>	>	<<	<	<<	>	<<	<<
GSHP	<	<<	<<	<<	<<	<<	<	=	<<	<<	<<	=	<<	<<
Air to water HP	=	<<	<<	<	<<	<<	>	>>	<<	<	<<	>	<<	<<
Portable ASHP	ND	ND	ND	ND	ND	ND	ND	ND	ND	ND	ND	ND	ND	ND
Water heater														
Electric tank	>>	<<	<<	>	<<	<	>>	>>	<<	>	<<	>>	<<	<
Electric tankless	>>	<<	<<	>	<<	<	>>	>>	<<	>	<<	>>	<<	<
Heat pump water heater	<	<<	<<	<<	<<	<<	<	=	<<	<<	<<	<	<<	<<
Heat pump water heater (120 V)	=	<<	<<	<	<<	<<	>	>	<<	<	<<	>	<<	<<
Solar water heater	<	<<	<<	<<	<<	<<	=	>	<<	<<	<<	=	<<	<<
GSHP desuperheater	<	<<	<<	<<	<<	<<	<	<	<<	<<	<<	<	<<	<<
Cooking ranges														
Electric coil range	>	<<	<<	<	<<	<<	>	>	<<	<	<<	>	<<	<<
Radiant range	>	<<	<<	<	<<	<<	>	>	<<	<	<<	>	<<	<<
Induction range	=	<<	<<	<	<<	<<	>	>	<<	<	<<	>	<<	<<
Portable induction cooker	=	<<	<<	<	<<	<<	>	>	<<	<	<<	>	<<	<<
Oven	ND	ND	ND	ND	ND	ND	ND	ND	ND	ND	ND	ND	ND	ND

APPENDIX

Equipment	AB	BC	MB	NB	NL	NT	NS	NU	ON	PE	QC	SK	YT	CA
Dryers														
Electric resistance	>>	<<	<<	>	<<	<	>>	>>	<<	>	<<	>>	<<	<
Condensing	>>	<<	<<	>	<<	<	>>	>>	<<	>	<<	>>	<<	<
Heat pump	>	<<	<<	=	<<	<	>>	>>	<<	=	<<	>>	<<	<<
120V	>>	<<	<<	>	<<	<	>>	>>	<<	>	<<	>>	<<	<
Combined washer and dryer	>>	<<	<<	>	<<	<	>>	>>	<<	>	<<	>>	<<	<
Fireplaces														
Electric fireplace	>	<<	<<	<	<<	<<	>	>>	<<	<	<<	>	<<	<<
Water vapour electric fireplace	>	<<	<<	<	<<	<<	>	>>	<<	<	<<	>	<<	<<
Barbeques														
Electric	>>	<<	<<	>	<<	<	>>	>>	<<	>	<<	>>	<<	<
Other equipment														
Electric pool heater	>>	<<	<<	>	<<	<	>>	>>	<<	>	<<	>>	<<	<<
Heat pump pool heater	<	<<	<<	<<	<<	<<	<	<	<<	<<	<<	<	<<	<<
Solar pool heater	<<	<<	<<	<<	<<	<<	<<	<<	<<	<<	<<	<<	<<	<<
EV chargers														
Level 1	<	<<	<<	<<	<<	<<	<	<	<<	<<	<<	<	<<	<<
Level 2	<	<<	<<	<<	<<	<<	<	<	<<	<<	<<	<	<<	<<
Bidirectional	<	<<	<<	<<	<<	<<	<	<	<<	<<	<<	<	<<	<<

Notes:

- >> the emissions are two or more times the emissions of comparable gas equipment.
- > the emissions are more than 10% over that of comparable gas equipment but less than double the emissions.
- = the emissions are within 10% of the emissions of comparable gas equipment.
- < the emissions are less 90% of the emissions of comparable gas equipment but less than half the emissions.
- << the emissions are half or less of the emissions of comparable gas equipment
- **ND** insufficient data available.

Endnotes

¹ Poirier and Cameron (2023). **The Case for Building Electrification in Canada**. The Transition Accelerator. Retrieved from <https://buildingdecarbonization.ca/wp-content/uploads/2023/07/The-Case-for-Building-Electrification-in-Canada-v1-1.pdf>

² Ontario Clean Air Alliance Research (2022). **An Analysis of the Financial and Climate Benefits of Using Ground Source Heat Pumps to Electrify Ontario’s Gas-Heated Homes**. Retrieved from <https://www.cleanairalliance.org/wp-content/uploads/2022/11/GSHP-final-report.pdf>

³ Canadian Climate Institute (2023) **Heat pumps pay off: unlocking lower cost heating and cooling in Canada**, Retrieved from <https://climateinstitute.ca/reports/heat-pumps-canada/>

⁴ Natural Resources Canada (2022). **Heating and Cooling with a Heat Pump**. Retrieved from <https://natural-resources.canada.ca/energy-efficiency/energy-star-canada/about/energy-star-announcements/publications/heating-and-cooling-heat-pump/6817#o2>

⁵ Oleson et al. (2022). **The Comfort Zone. International Network for Sustainable Energy**. Retrieved from <https://www.coolproducts.eu/wp-content/uploads/2022/02/EEB-Heat-Pump-Comfort-Audit-Report.pdf>

⁶ Natural Resources Canada (2022). **Heating and cooling with a heat pump**. Retrieved from <https://www.nrcan.gc.ca/energy-efficiency/energy-star-canada/about/energy-star-announcements/publications/heating-and-cooling-heat-pump/6817>

⁷ Looking for either **313D- residential air condition systems mechanic license** or **313A – refrigeration and air conditioning systems mechanic license**

⁸ Sawa, D.B. (2015). **My kitchen gallery: James Ramsden**. The Guardian. Retrieved from <https://www.theguardian.com/lifeandstyle/gallery/2015/aug/18/my-kitchen-gallery-james-ramsdn>

⁹ Gruenwald, T. et al., (2023). **Population Attributable Fraction of Gas Stoves and Childhood Asthma in the United States**. International Journal of Environmental Research and Public Health 20, no. 1: 75. <https://doi.org/10.3390/ijerph20010075>

¹⁰ T. Campi et al. (2023). **A Simulation Model for EMC Compliance Assessment of Induction Cooktops for Cardiac Implanted Electronic Devices**. Retrieved from https://ieeexplore.ieee.org/abstract/document/10265533?casa_token=wuUHwno41VMAAAA:bLSZLTsleZT32Y7MF8JyTEH82dY56iz5ZBDRgkwwDirRNPAFKcDIp4KjuZITfIJZF-XdCWFJ-w

¹¹ Natural Resources Canada (2019). **National Energy Use Database**. 2019 Survey of Household Energy Use (SHEU-2019) Data Tables. Table 14.1a – Outdoor Equipment By Region. Retrieved from <https://oee.nrcan.gc.ca/corporate/statistics/neud/dpa/showTable.cfm?type=SH§or=aaa&juris=ca&year=2019&rn=111&page=1>

¹² See the **jurisdictional scan on p11-12 of City of Toronto**. (2023). Two-stroke engine small equipment: steps to pursue a ban. Retrieved from <https://www.toronto.ca/legdocs/mmis/2023/ie/bgrd/backgroundfile-237510.pdf>

¹³ Dutzik, Sokolow, Metzger, Shatz (October 2023). **Lawn Care Goes Electric. Why it’s time to switch to a new generation of clean, quiet electric lawn equipment**. Retrieved from <https://publicinterestnetwork.org/wp-content/uploads/2023/10/Lawn-Care-Goes-Electric-Oct23.pdf>

ENDNOTES

¹⁴ Eaton (n.d.) Blackout tracker: **Canada annual report 2017**. Retrieved from <https://www.eaton.com/content/dam/eaton/products/backup-power-ups-surge-it-power-distribution/backup-power-ups/blackout-tracker-/eaton-blackout-tracker-annual-report-canada-2017.pdf>

¹⁵ Canada Energy Regulator (2018). **Market Snapshot: Residential solar is financially viable in some provinces and territories, but not in others**. Retrieved from <https://www.cer-rec.gc.ca/en/data-analysis/energy-markets/market-snapshots/2018/market-snapshot-residential-solar-is-financially-viable-in-some-provinces-territories-but-not-in-others.html>

¹⁶ Bluewater Energy (2024). **How do solar panels increase the value of your property?** Retrieved from <https://bluewaterenergy.ca/how-do-solar-panels-increase-the-value-of-your-property/>

¹⁷ National Renewable Energy Laboratory (2023). **Unlocking the Value of Deep Energy Retrofits. Recommendations for Creating Financial Products to Reduce Building Emissions and Improve Returns to Multifamily Building Owners**. Retrieved from <https://www.nrel.gov/docs/fy24osti/84912.pdf>

¹⁸ Natural Resources Canada (2024). **National Energy Use Database. Directory of Energy Efficiency and Alternative Energy Programs in Canada**. Retrieved from https://oee.nrcan.gc.ca/corporate/statistics/neud/dpa/policy_e/results.cfm?attr=0

¹⁹ Energy Hub. (2024). **Clean energy incentives & rebates**. Retrieved from <https://www.energyhub.org/incentives/>

²⁰ Dunsky Energy + Climate Advisors (2023). **Scaling Heat Pump Retrofits through Aggregation and Bulk Procurement**. Retrieved from https://taf.ca/custom/uploads/2023/04/TAF-HP-Aggregation-Final-Report_Final.pdf

²¹ Pacific Gas and Electric Company. (2023). **Induction cooktop lending program**. Retrieved from <https://www.etcc-ca.com/reports/induction-cooktop-lending-program>

²² **An example is the Heat pumps for homes Canada facebook group:** <https://www.facebook.com/groups/6678699425562406>

